

CAPÍTULO



03



Optimizadores de lineal (Organización de espacios)

OPTIMIZADORES DE LINEAL	100 - 148
ORGANIZADORES A MEDIDA	149 - 152
DISPENSADORES DE PRODUCTOS A GRANEL	153
DISPENSADOR <i>GENBOX</i>	154 - 158
DISPENSADOR <i>TURNOFLEX</i>	159 - 160
ACCESORIOS	161 - 163
<i>QUICKBOX - PRIBOX</i>	164

OPTIMIZADORES DE LINEAL

El orden y la presentación del producto son los protagonistas del lineal.

Manteniendo tus productos organizados en las estanterías de tu comercio, darás una mejor imagen y te organizarás mejor para vender, localizar productos con rotura de stock y para hacer inventario.

Nuestra selección abarca desde separadores hasta falseadores, empujadores o raíles; los cuales permiten ofrecer una gran variedad de soluciones en modelos y medidas para cada producto.



▶ OPTIMIZACIÓN DE LINEAL - SEPARADORES *SNAP-ON*

SEPARADOR *SNAP-ON*:

- Disponemos de una gran variedad de modelos de separadores.
- Diferentes posiciones (izquierdo, derecho, central).
- Varias medidas disponibles
- Divisibles - rompibles, con o sin ángulo.

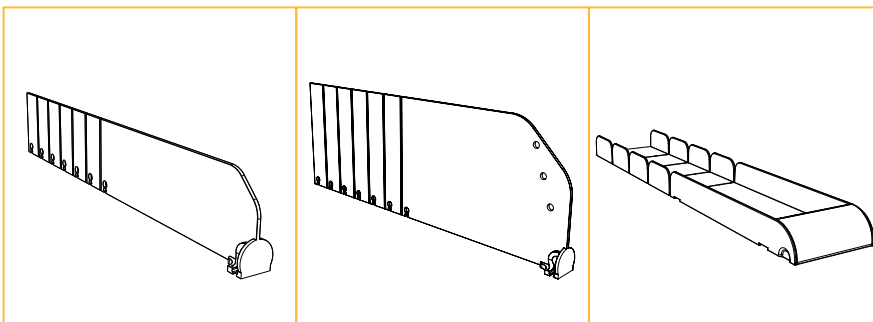
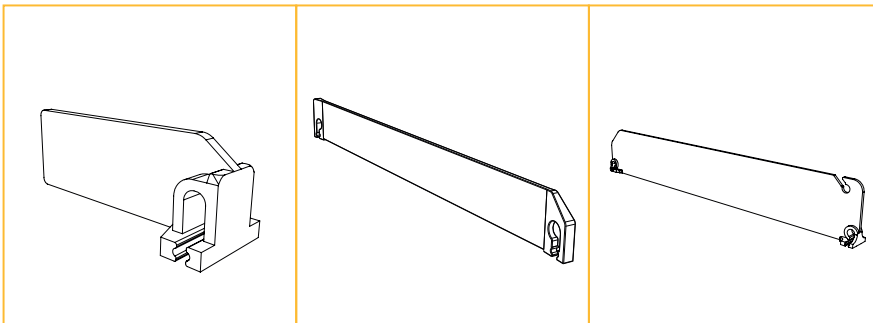
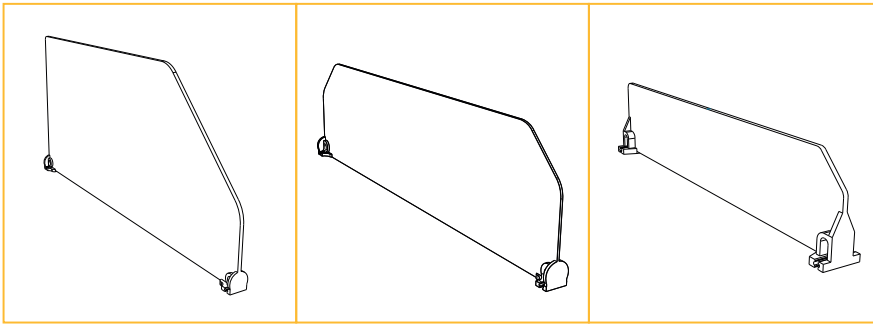

▶ OPTIMIZACIÓN DE LINEAL - SEPARADORES *SNAP-ON*

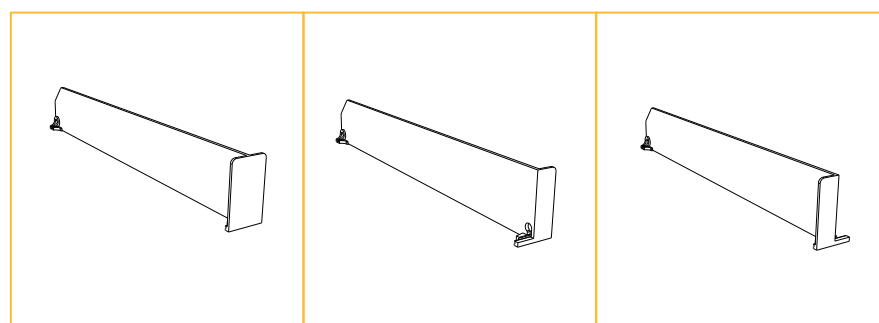
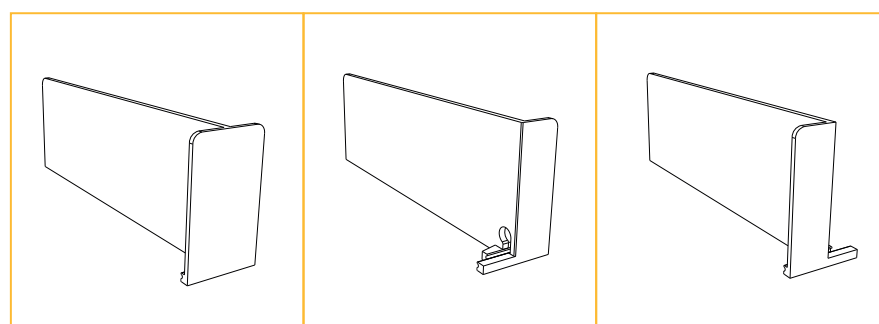
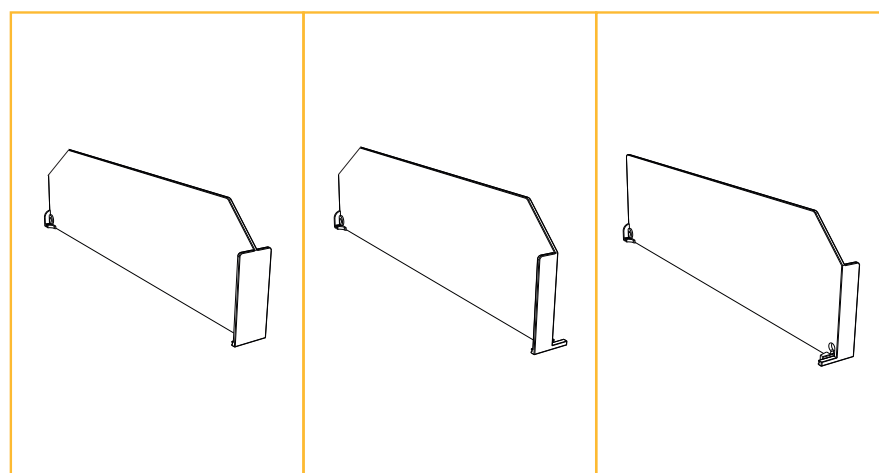
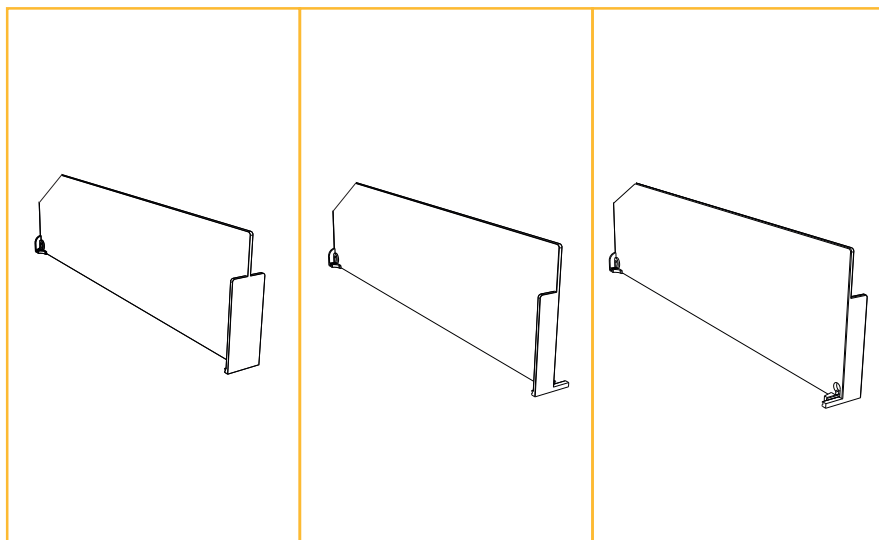

SEPARADOR *SNAP-ON*: Frontal central de 60 mm

CARACTERÍSTICAS

A	B	Ref.	Uds. p/caja
60 mm	185 mm	V0560103184	50
60 mm	285 mm	V0560101031	100
60 mm	385 mm	V0560101037	100
60 mm	410 mm	V0560101019	100
60 mm	485 mm	V0560101038	100
60 mm	585 mm	V0560101039	100

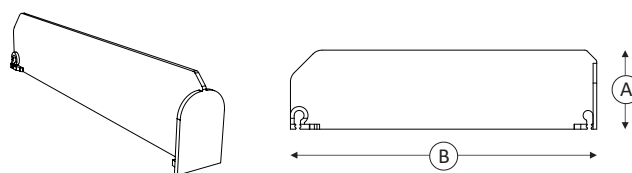

*Consultar otras medidas

SEPARADOR *SNAP-ON*: Frontal izquierdo de 60 mm

CARACTERÍSTICAS

A	B	Ref.	Uds. p/caja
60 mm	185 mm	V0560103185	50
60 mm	285 mm	V0560101074	100
60 mm	385 mm	V0560101080	100
60 mm	410 mm	V0560103020	100
60 mm	485 mm	V0560101082	100
60 mm	585 mm	V0560101084	100

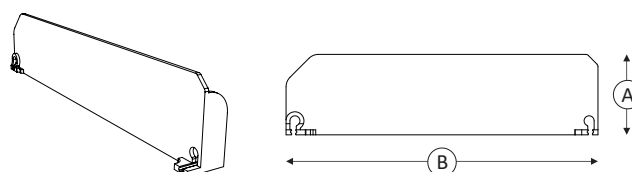

*Consultar otras medidas

SEPARADOR *SNAP-ON*: Frontal derecho de 60 mm

CARACTERÍSTICAS

A	B	Ref.	Uds. p/caja
60 mm	185 mm	V0560103186	50
60 mm	285 mm	V0560101056	100
60 mm	385 mm	V0560101061	100
60 mm	410 mm	V0560103021	100
60 mm	485 mm	V0560101062	100
60 mm	585 mm	V0560101063	100

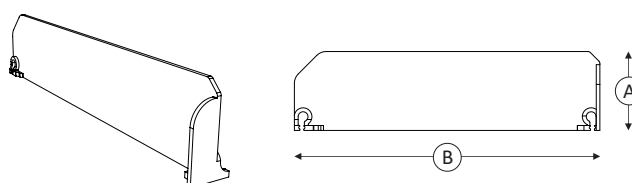

*Consultar otras medidas

SEPARADOR 25 mm

CARACTERÍSTICAS

A	B	Ref.	Uds. p/caja
25 mm	72 mm	V0560101011	800

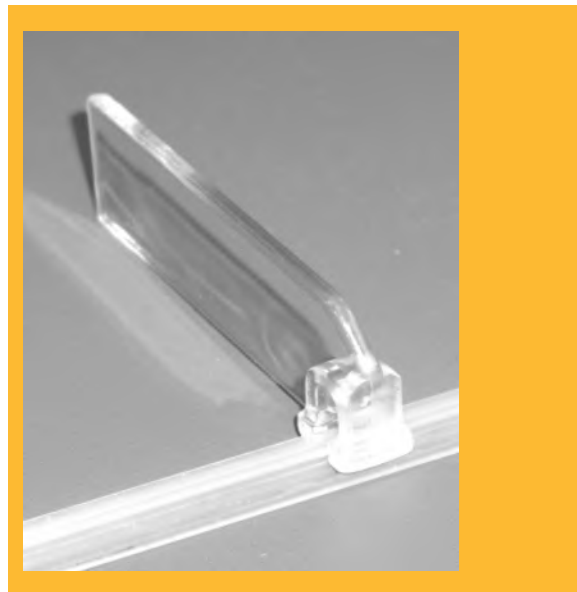
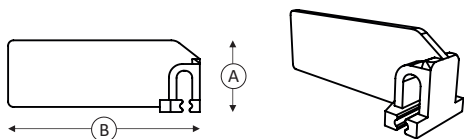

SEPARADOR 200 - 300 mm

CARACTERÍSTICAS

A	B	Ref.	Uds. p/caja
200 mm	385 mm	V0560100969	50
200 mm	435 mm	V0560100989	50
200 mm	485 mm	V0560100996	50
200 mm	535 mm	V0560101000	50
200 mm	585 mm	V0560101004	50
300 mm	435 mm	V0560100922	50
300 mm	535 mm	V0560100923	50

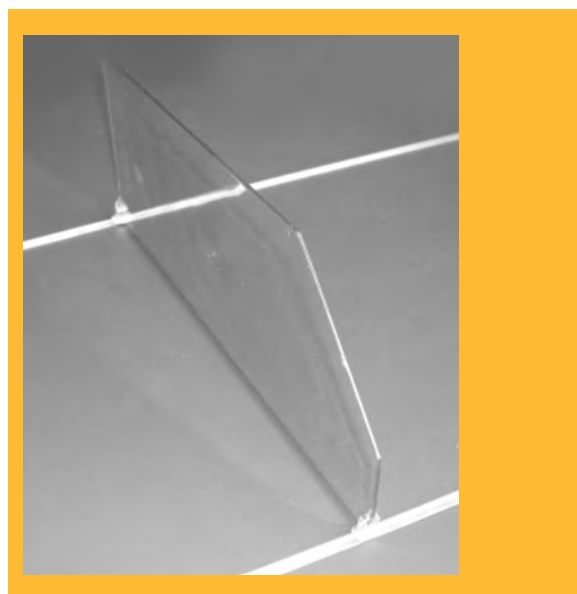
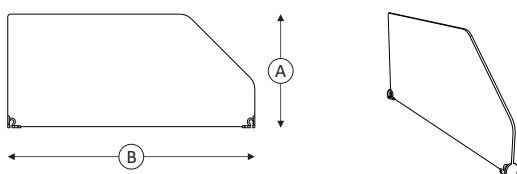

SEPARADOR 45 - 120 mm

CARACTERÍSTICAS

A	B	Ref.	Uds. p/caja
45 mm	277 mm	V0560100957	100
45 mm	345 mm	V0560100964	100
45 mm	445 mm	V0560100990	100
45 mm	543 mm	V0560101002	150

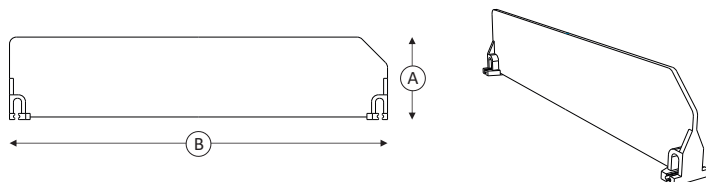



Consultar otras medidas

SEPARADOR 2002 PT 25 mm

CARACTERÍSTICAS

A	B	Ref.	Uds. p/caja
25 mm	185 mm	V0560100953	200
25 mm	275 mm	V0560102916	200
25 mm	335 mm	V0560102910	200
25 mm	435 mm	V0560102912	200
25 mm	535 mm	V0560102914	200

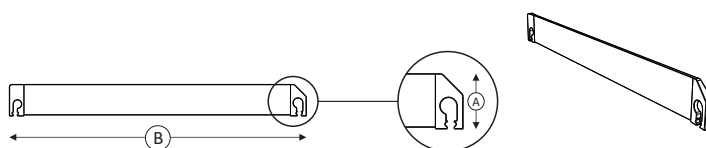

SEPARADOR 2002 PT 60 mm

CARACTERÍSTICAS

A	B	Ref.	Uds. p/caja
60 mm	185 mm	V0560102638	20
60 mm	285 mm	V0560100936	20
60 mm	385 mm	V0560100940	20
60 mm	485 mm	V0560100942	20
60 mm	585 mm	V0560100945	40

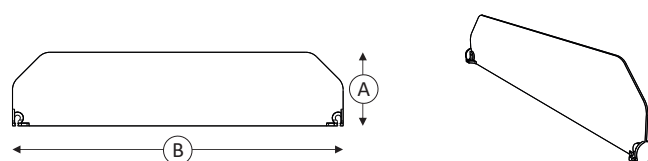

Consultar otras medidas

SEPARADOR 2002 PT 60 - 120 mm

CARACTERÍSTICAS

A	B	Ref.	Uds. p/caja
120 mm	185 mm	V0560102639	20
120 mm	285 mm	V0560100933	20
120 mm	385 mm	V0560100937	20
60 mm	485 mm	V0560100944	20
60 mm	585 mm	V0560100946	40

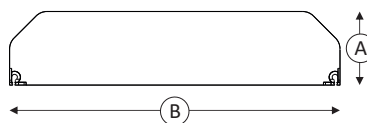

Consultar otras medidas

SEPARADOR *SNAP-ON*: Central 60 mm

CARACTERÍSTICAS			
A	B	Ref.	Uds. p/caja
60 mm	235 mm	V0560105150	50
60 mm	335 mm	V0560105153	50
60 mm	285 mm	V0560105913	50
60 mm	385 mm	V0560103407	50

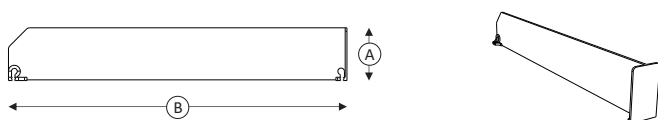

Consultar otras medidas

SEPARADOR *SNAP-ON*: Izquierdo 60 mm

CARACTERÍSTICAS			
A	B	Ref.	Uds. p/caja
60 mm	235 mm	V0560105151	50
60 mm	335 mm	V0560105154	50
60 mm	285 mm	V0560105915	50
60 mm	385 mm	V0560103406	50

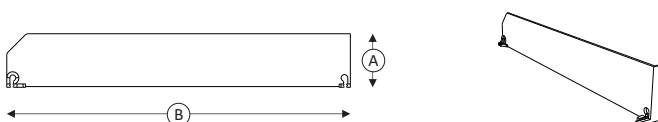

Consultar otras medidas

SEPARADOR *SNAP-ON*: Derecho 60 mm

CARACTERÍSTICAS			
A	B	Ref.	Uds. p/caja
60 mm	235 mm	V0560105152	50
60 mm	335 mm	V0560105155	50
60 mm	285 mm	V0560105914	50
60 mm	385 mm	V0560103408	50

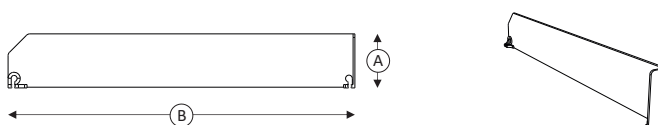

Consultar otras medidas



SEPARADOR *SNAP-ON*: Frontal-derecho 80 mm

CARACTERÍSTICAS			
A	B	Ref.	Uds. p/caja
120 mm	275 mm	V0560102969	50
120 mm	345 mm	V0560102968	50
120 mm	410 mm	V0560102971	50
120 mm	485 mm	V0560101081	50
120 mm	585 mm	V0560101083	50

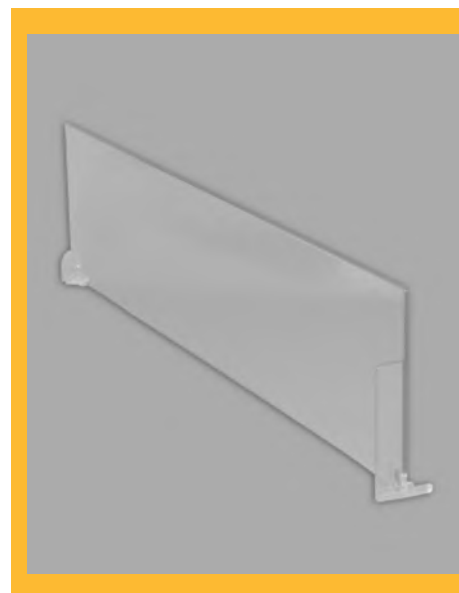
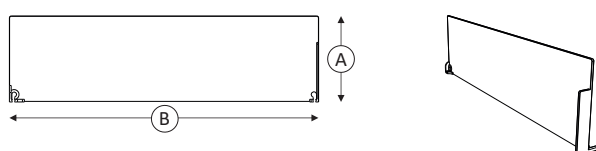

Consultar otras medidas

Trasera a 45°

CARACTERÍSTICAS			
A	B	Ref.	Uds. p/caja
120 mm	235 mm	V0560102970	50
120 mm	335 mm	V0560102967	50
120 mm	385 mm	V0560101079	50

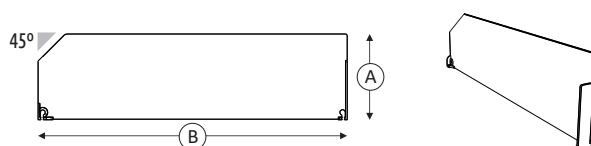

SEPARADOR *SNAP-ON*: Frontal-central 80 mm

CARACTERÍSTICAS			
A	B	Ref.	Uds. p/caja
120 mm	275 mm	V0560102935	60
120 mm	345 mm	V0560102933	50
120 mm	410 mm	V0560102937	50
120 mm	485 mm	V0560102784	50
120 mm	585 mm	V0560102785	50

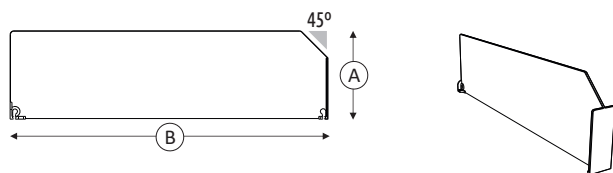

Consultar otras medidas

Ambos lados a 45°

CARACTERÍSTICAS			
A	B	Ref.	Uds. p/caja
120 mm	235 mm	V0560102936	50
120 mm	335 mm	V0560102932	50
120 mm	385 mm	V0560101024	50

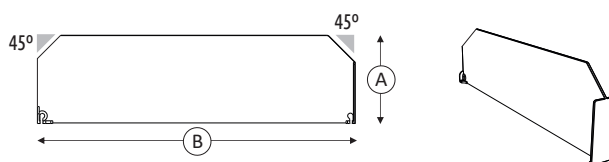



Consultar otras medidas

SEPARADOR *SNAP-ON*: Frontal-izquierdo 80 mm

CARACTERÍSTICAS

A	B	Ref.	Uds. p/caja
120 mm	275 mm	V0560102954	50
120 mm	345 mm	V0560102952	50
120 mm	410 mm	V0560102956	50
120 mm	485 mm	V0560102981	50
120 mm	585 mm	V0560102892	50

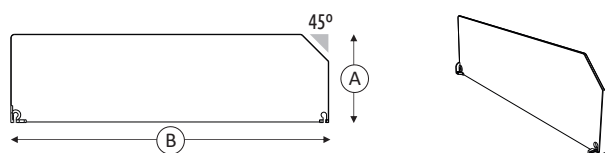

Ambos lados a 45°

CARACTERÍSTICAS

A	B	Ref.	Uds. p/caja
120 mm	235 mm	V0560102955	50
120 mm	335 mm	V0560102951	50
120 mm	385 mm	V0560102890	50

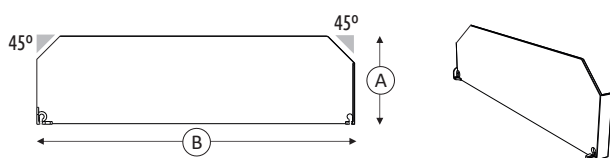

SEPARADOR *SNAP-ON*: Frontal-derecho 80 mm

CARACTERÍSTICAS

A	B	Ref.	Uds. p/caja
120 mm	275 mm	V0560102976	50
120 mm	345 mm	V0560102974	50
120 mm	410 mm	V0560102978	50
120 mm	485 mm	V0560102886	50
120 mm	585 mm	V0560102887	50

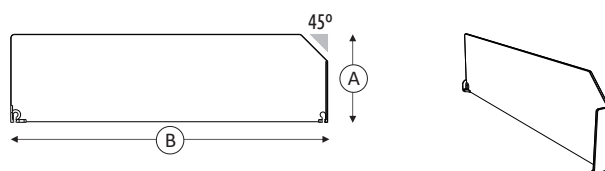

Consultar otras medidas

Ambos lados a 45°

CARACTERÍSTICAS

A	B	Ref.	Uds. p/caja
120 mm	235 mm	V0560102977	50
120 mm	335 mm	V0560102973	50
120 mm	385 mm	V0560102885	50

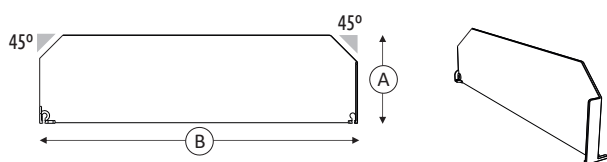

SEPARADOR 2002 PT 120 mm

CARACTERÍSTICAS

A	B	Ref.	Uds. p/caja
120 mm	435 mm	V0560100986	50
120 mm	485 mm	V0560100994	50
120 mm	535 mm	V0560100998	50

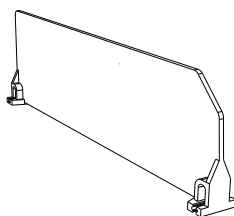
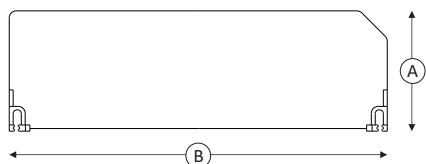

SEPARADOR 45 mm

CARACTERÍSTICAS

A	B	Ref.	Uds. p/caja
45 mm	277 mm	V0560100957	100
45 mm	345 mm	V0560100964	100
45 mm	445 mm	V0560100990	100
45 mm	543 mm	V0560101002	150

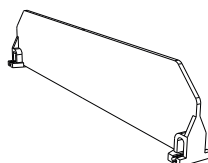
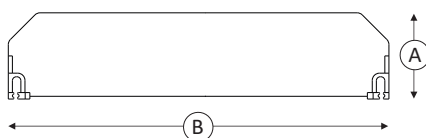

SEPARADOR 60 mm

CARACTERÍSTICAS

A	B	Ref.	Uds. p/caja
60 mm	385 mm	V0560103405	75

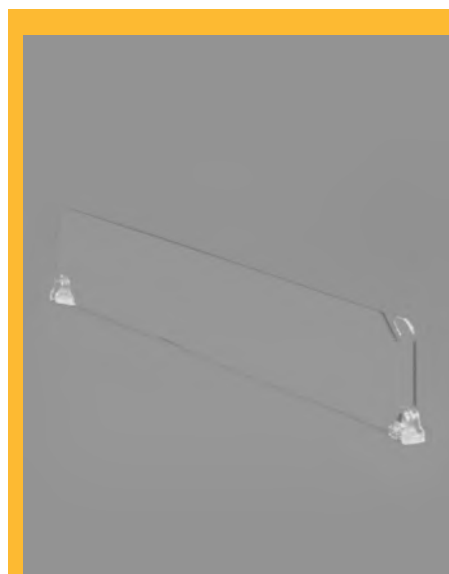
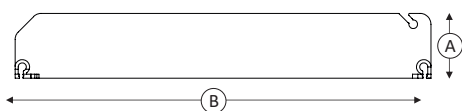

SEPARADORES
DE COLORES

ACABADOS
TRANSLÚCIDOS
U OPACOS



FRONTALES para divisores centrales de 120 mm

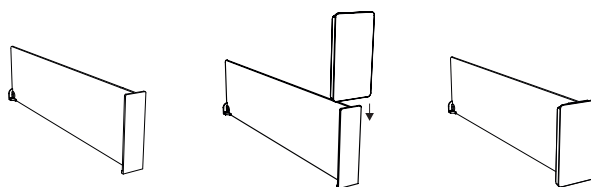

CARACTERÍSTICAS

A	B	Ref.	Uds. p/caja
62 mm	120 mm	V0560106758	150

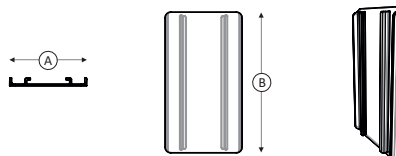

Sacos para Gelo

62mm



SEPARADOR *SNAP-ON*: Frontal-central 120 mm

CARACTERÍSTICAS			
A	B	Ref.	Uds. p/caja
120 mm	275 mm	V0560102922	50
120 mm	345 mm	V0560102920	50
120 mm	410 mm	V0560102924	50
120 mm	485 mm	V0560102780	50
120 mm	585 mm	V0560102781	50

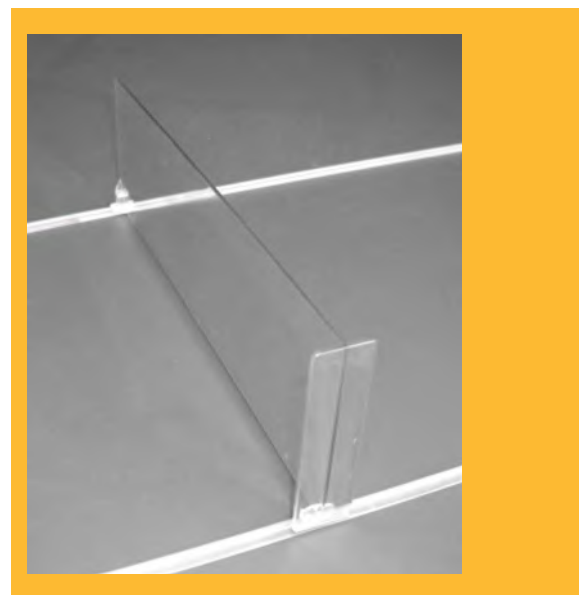
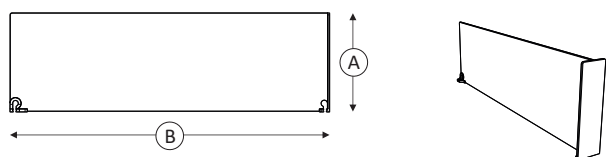

Consultar otras medidas

Trasera a 45°

CARACTERÍSTICAS			
A	B	Ref.	Uds. p/caja
120 mm	235 mm	V0560102923	50
120 mm	335 mm	V0560102898	50
120 mm	385 mm	V0560105162	50

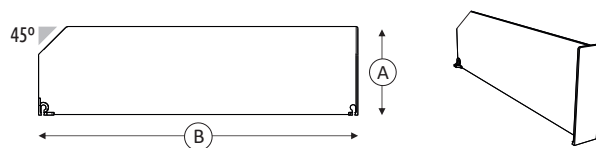

SEPARADOR *SNAP-ON*: Frontal-izquierdo 120 mm

CARACTERÍSTICAS			
A	B	Ref.	Uds. p/caja
120 mm	275 mm	V0560102941	50
120 mm	345 mm	V0560102939	50
120 mm	410 mm	V0560102943	50
120 mm	485 mm	V0560102882	50
120 mm	585 mm	V0560102883	50

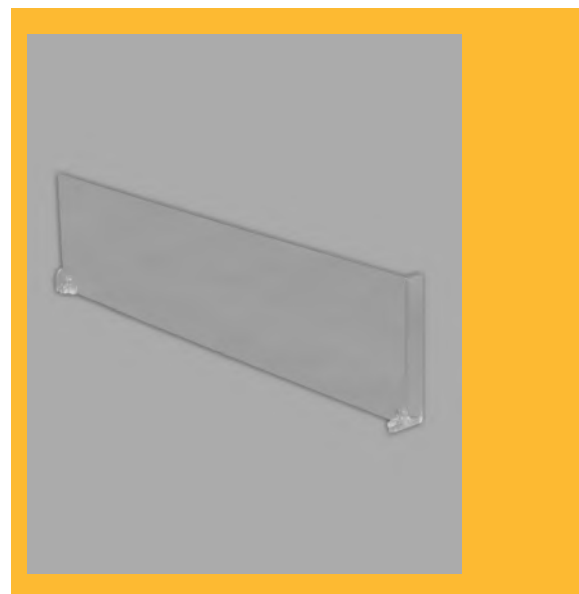
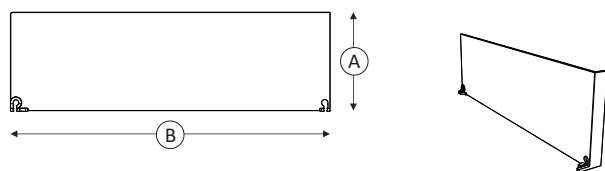

*Consultar otras medidas

Trasera a 45°

CARACTERÍSTICAS			
A	B	Ref.	Uds. p/caja
120 mm	235 mm	V0560102942	50
120 mm	335 mm	V0560102938	50
120 mm	385 mm	V0560102881	50

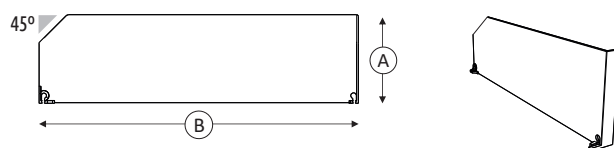

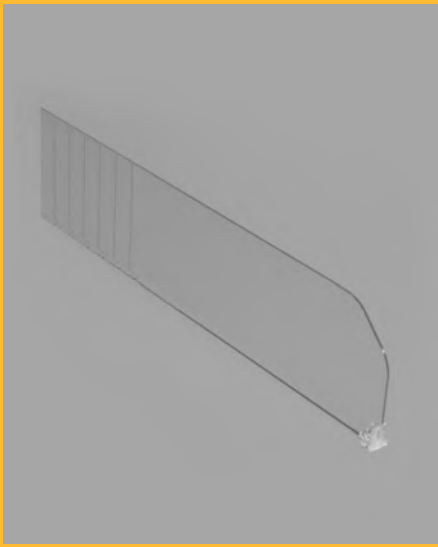

Consultar otras medidas

SEPARADOR DIVISIBLE

CARACTERÍSTICAS

A	B	Ref.	Uds. p/caja
25 mm	335-485 mm	V0560100962	50
60 mm	185-335 mm	V0560100928	20
60 mm	485-635 mm	V0560100993	20
120 mm	335-485 mm	V0560100961	50
120 mm	485-635 mm	V0560100991	20

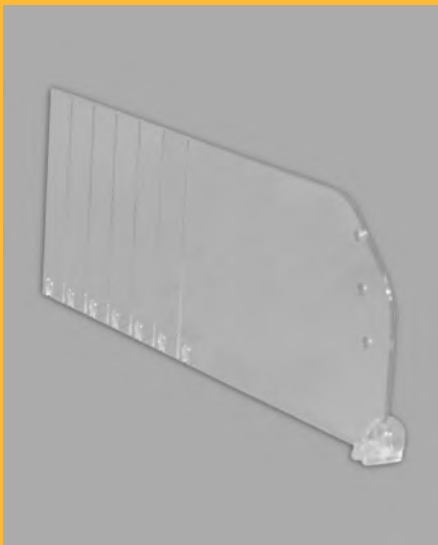
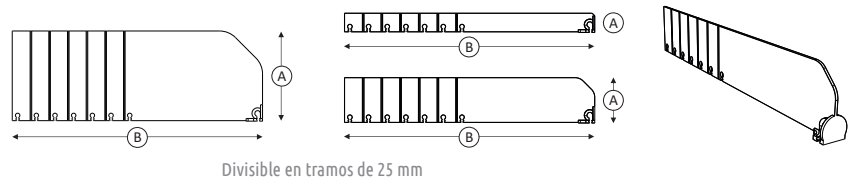

Consultar otras medidas

SEPARADOR DIVISIBLE 120 mm

CARACTERÍSTICAS

A	B	Ref.	Uds. p/caja
120 mm	185-335 mm	V0560104328	20
120 mm	335-485 mm	V0560104329	50
120 mm	485-635 mm	V0560104330	20

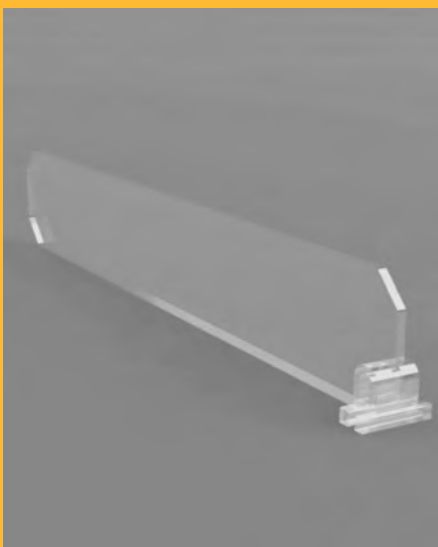
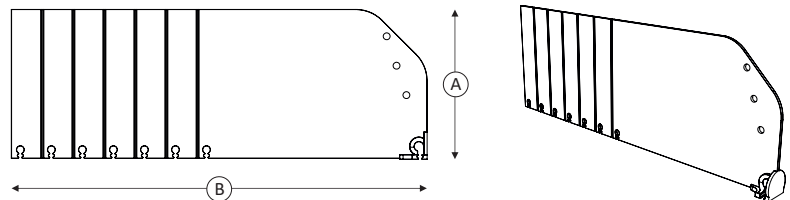

SEPARADOR 45 mm

CARACTERÍSTICAS

A	B	Ref.	Uds. p/caja
45 mm	285 mm	V0560104343	50

C/ trasero SNAP-ON

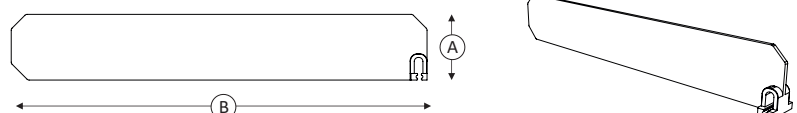





SISTEMA ESPECIAL PARA PIZZAS

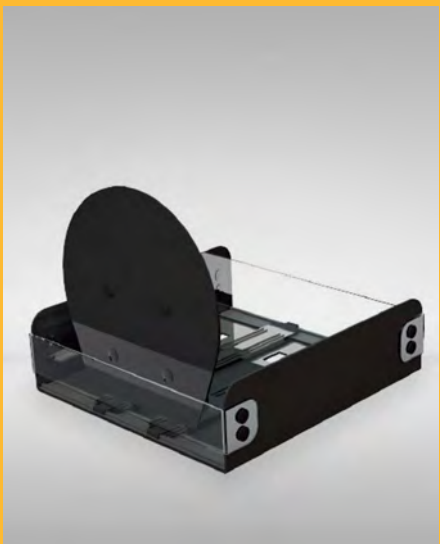

Empujador pizza *SNAP-ON*: Duo HIPS

CARACTERÍSTICAS

Dimensiones	FUERZA (Newton)	Ref.
485x270	12 N	V0560118931
485x310	12 N	V0560118932

EMPUJADOR PARA PIZZA - SIMPLE (*Clear*)

CARACTERÍSTICAS

A	FUERZA (Newton)	Ref.	Uds. p/caja
335 mm	12 N	V0560107234	50
385 mm	12 N	V0560107233	60
435 mm	12 N	V0560107243	50
485 mm	12 N	V0560107258	50

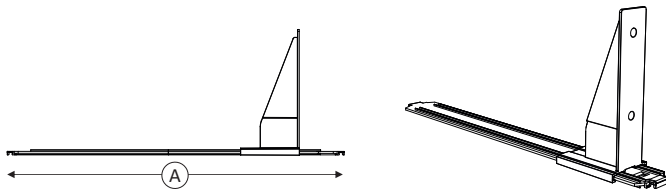

EMPUJADOR PARA PIZZA - DOBLE (*White*)

CARACTERÍSTICAS

A	FUERZA (Newton)	Ref.	Uds. p/caja
235 mm	12 N	V0560108167	15
335 mm	12 N	V0560107228	15
385 mm	12 N	V0560107227	15
435 mm	12 N	V0560107244	12
485 mm	12 N	V0560107257	12
535 mm	12 N	V0560108120	12
585 mm	12 N	V0560108121	12

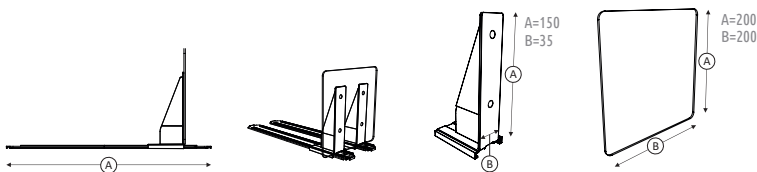



Consultar otras medidas

EMPUJADOR ADAPTABLE (*Clear*)

CARACTERÍSTICAS

A	FUERZA (Newton)	Ref.	Uds. p/caja
285 mm	12 N	V0560100893	100
285 mm	9 N	V0560100894	100
385 mm	12 N	V0560100899	100
385 mm	9 N	V0560100900	100
385 mm	6 N	V0560102637	100
485 mm	12 N	V0560100906	50
485 mm	9 N	V0560100907	50

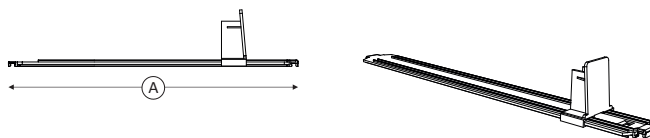

EMPUJADOR *TOBACCO* (*Clear*)

Ref.	Uds. p/caja
V0560101205	1000

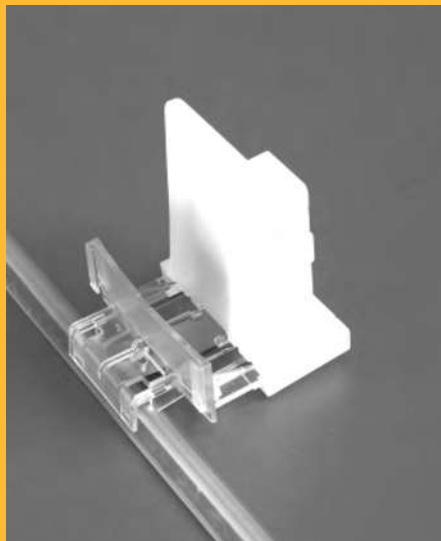
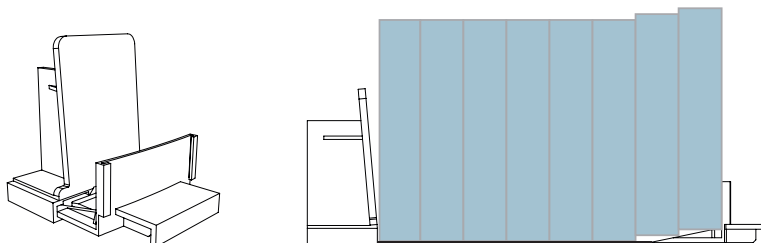



PLACA TRASERA (*Clear*)

CARACTERÍSTICAS

A	B	Ref.	Uds. p/caja
100 mm	50 mm	V0560101252	60

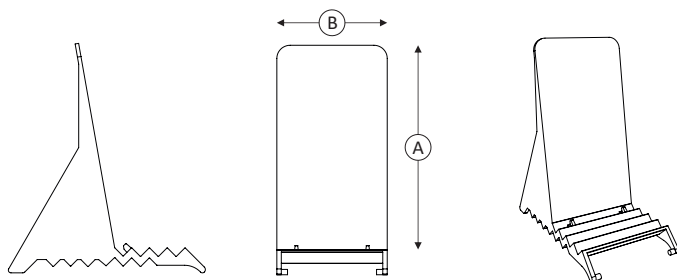

BASE ROMPIBLE / DIVISIBLE (*Clear*)

CARACTERÍSTICAS

A	Ref.	Uds. p/caja
511 mm	V0560101106	60

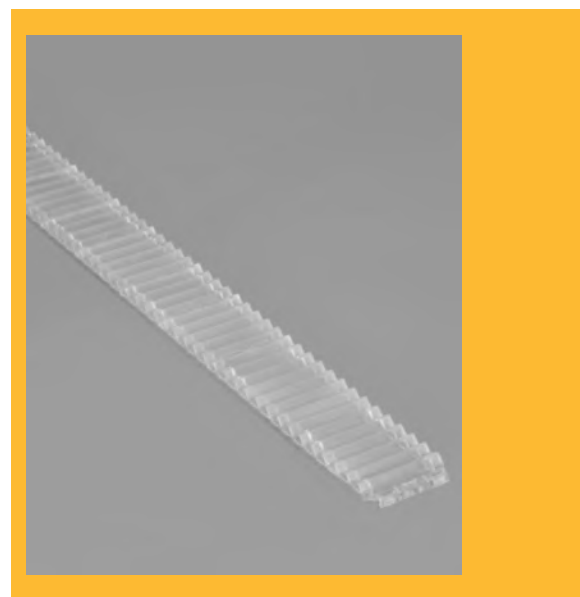
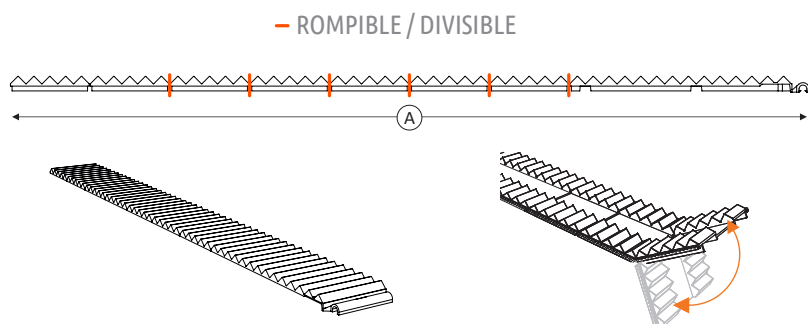



SISTEMA *TIRETTE* - PLACA TRASERA (Clear)

CARACTERÍSTICAS

A	B	Ref.	Uds. p/caja
120 mm	60 mm	V0560101254	60

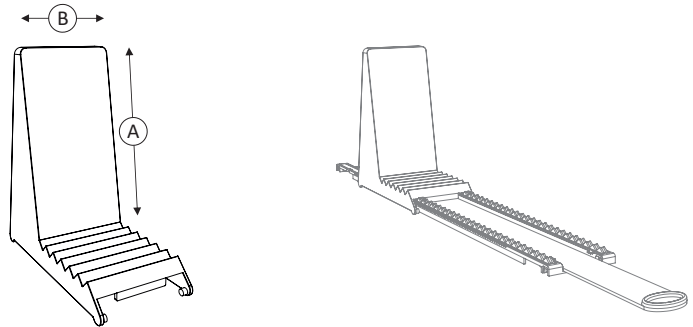

SISTEMA *TIRETTE* - BASE (Clear)

CARACTERÍSTICAS

A	Ref.	Uds. p/caja
385 mm	V0560100916	60
485 mm	V0560100917	60

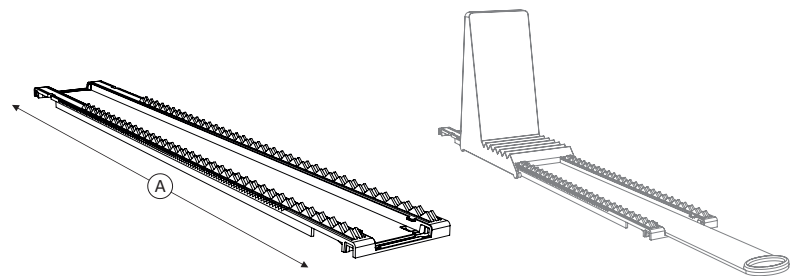

SISTEMA *TIRETTE* - ALIMENTADOR (Clear)

CARACTERÍSTICAS

A	Ref.	Uds. p/caja
385 mm	V0560101202	60
485 mm	V0560101203	60

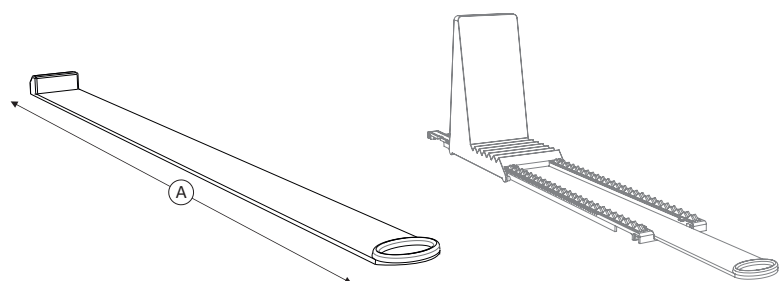

SISTEMA *TIRETTE* - Soporte trasero de 95 mm (*Clear*)

CARACTERÍSTICAS

A	B	Ref.	Uds. p/caja
125 mm	98 mm	V0560109661	60

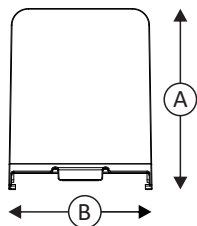

¡NUEVO!



SISTEMA *TIRETTE* - BASE Soporte trasero de 95 mm (*Clear*)

CARACTERÍSTICAS

C	D	Ref.	Uds. p/caja
500 mm	95 mm	V0560109857	60

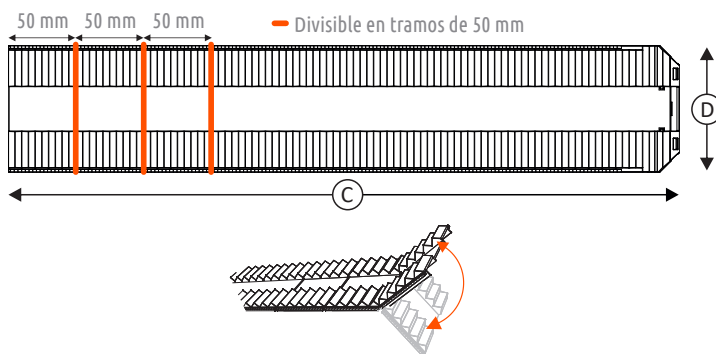

SISTEMA *TIRETTE* - ALIMENTADOR

CARACTERÍSTICAS

E	F	Ref.	Uds. p/caja
32 mm	485 mm	V0560101203	60
32 mm	385 mm	V0560101202	60

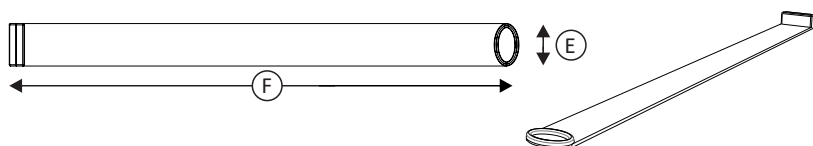



¡NUEVO!

SOPORTE TRASERO DE 99 mm



BASE PARA SOPORTE DE 99 mm

Simple
Magnético

CARACTERÍSTICAS				
	A	B	Ref.	Uds. p/caja
Simple	125 mm	98 mm	V0560110276	200
Magnético	125 mm	98 mm	V0560110274	100

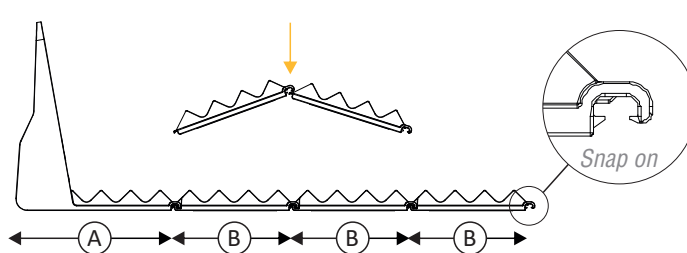

SOPORTE DE 99 mm

Simple
Magnético

CARACTERÍSTICAS				
	C	D	Ref.	Uds. p/caja
Simple	385 mm	95 mm	V0560110275	60
Magnético	385 mm	95 mm	V0560110273	60

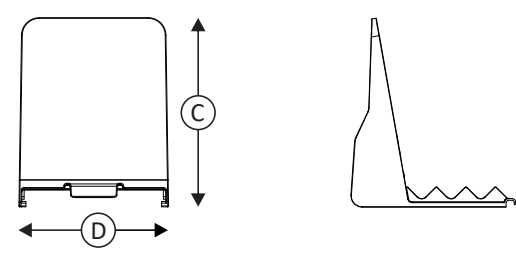



▶ OPTIMIZACIÓN DE LINEAL-EMPUJADOR GRAVITATORIO PARA SISTEMA *SNAP-ON*



BASE PARA SISTEMA POR GRAVEDAD (*Clear*)

CARACTERÍSTICAS

A	Ref.	Uds. p/caja
385 mm	V0560100901	75
435 mm	V0560104303	75
485 mm	V0560100908	75
585 mm	V0560104732	90

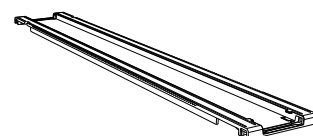
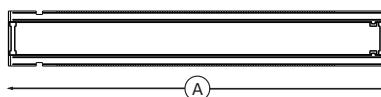

PLACA TRASERA PARA SISTEMA DE GRAVEDAD (*White*)

CARACTERÍSTICAS

A	B	Ref.	Uds. p/caja
150 mm	95 mm	V0560101253	50

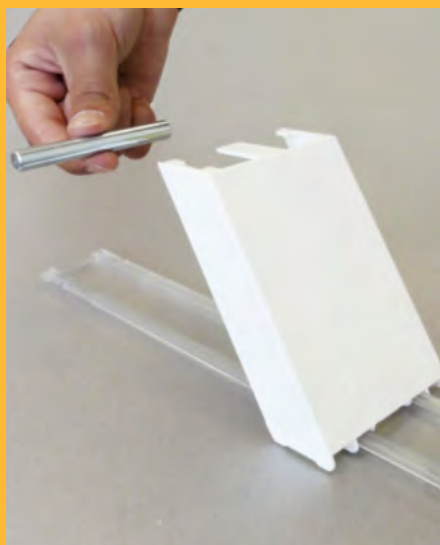
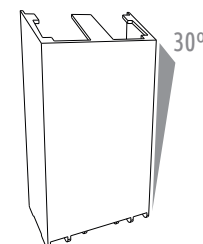
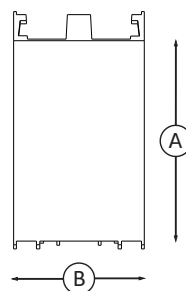

CONTRAPESO PARA SISTEMA POR GRAVEDAD (*Chrome*)

CARACTERÍSTICAS

A	∅	Ref.	Uds. p/caja
84 mm	10 mm	V0560401201	500

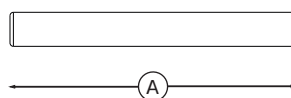

kg
52 g

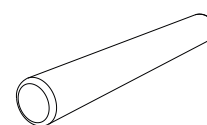

▶ OPTIMIZACIÓN DE LINEAL - PERFILES *SNAP-ON*

PERFIL DELANTERO (magnético o adhesivo)

CARACTERÍSTICAS

	A	B	Color	Ref.	Uds. p/caja
Adhesivo	80 mm	1000 mm	BLANCO ○	V0560203003	50
	30 mm	1000 mm	BLANCO ○	V0560201113	100
	60 mm	1000 mm	TRANSP. ○	V0560201123	50
Magnético	30 mm	1000 mm	BLANCO ○	V0560201115	50
	60 mm	1000 mm	BLANCO ○	V0560201122	100
	80 mm	1000 mm	BLANCO ○	V0560203000	25

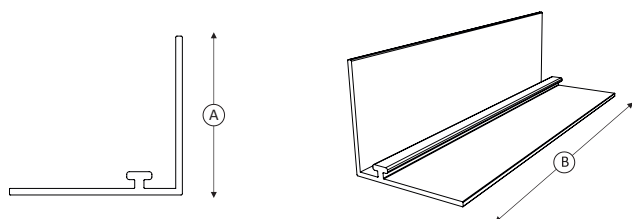

Consultar otras medidas

PERFIL DELANTERO con adhesivo (*Clear*)

CARACTERÍSTICAS

A	B	C	Ref.	Uds. p/caja
23 mm	1000 mm	13 mm	V0560201125	200

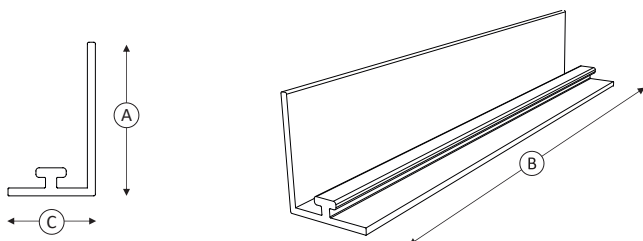

PERFIL DELANTERO para marca 25 mm (*White*)

CARACTERÍSTICAS

	A	B	Ref.	Uds. p/caja
*Adh.	25 mm	1000 mm	V0560203902	50
*Mag.	25 mm	1000 mm	V0560203903	50

*magnético o adhesivo

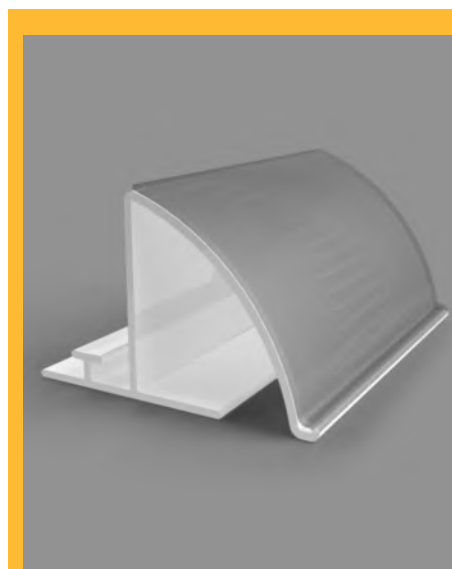
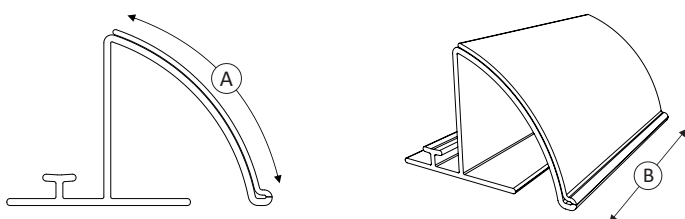

*Consultar otras medidas

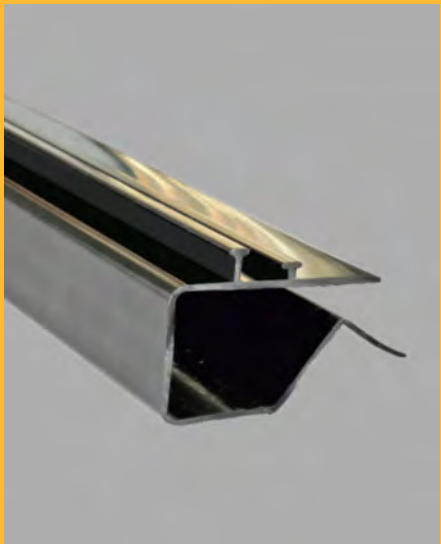

*Consultar otras medidas

PERFIL DELANTERO

CARACTERÍSTICAS

A	B	Color	Ref.	Uds. p/caja
27 mm	995 mm	NEGRO ●	V0560206789	25
27 mm	1000 mm	R9010 ○	V0560206718	25
31,5 mm	1000 mm	R9010 ○	V0560206719	25

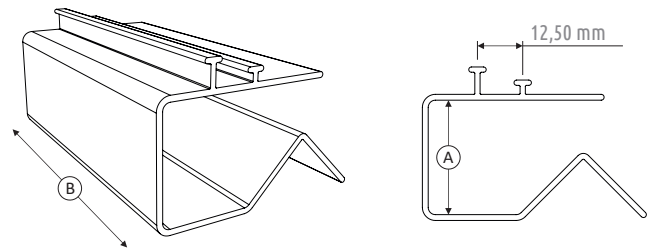

PERFIL DELANTERO para TEGO / MAFIROL (*Clear*)

CARACTERÍSTICAS

A	B	Ref.	Uds. p/caja
13,5 mm	1000 mm	V0560201126	200

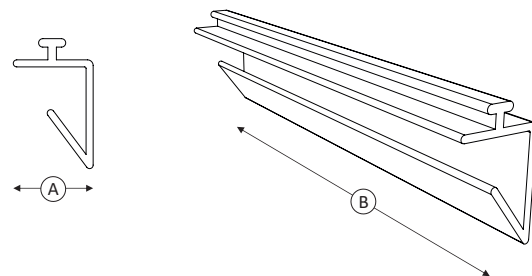

PERFIL DELANTERO para TEGO / MAFIROL (*Clear*)

CARACTERÍSTICAS

A	B	Ref.	Uds. p/caja
20 mm	1000 mm	V0560201110	100

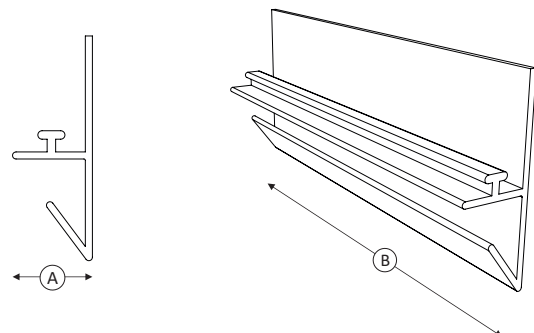

▶ OPTIMIZACIÓN DE LINEAL - PERFILES *SNAP-ON*

PERFIL TRASERO 30 mm (Imán o adhesivo)

CARACTERÍSTICAS

	A	B	Ref.	Uds. p/caja	
Imán Adhesivo	30 mm	1000 mm	V0560201111	300	(White)
	30 mm	1000 mm	V0560201117	100	(White)
	30 mm	1000 mm	V0560201119	300	(Clear)

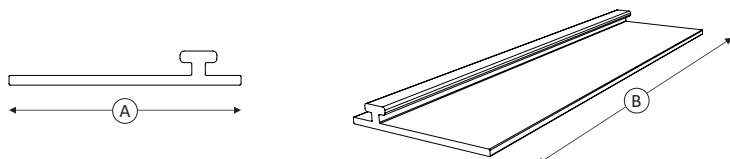

PERFIL TRASERO 11,5 mm (Clear)

CARACTERÍSTICAS

	A	B	Ref.	Uds. p/caja
Adhesivo	11,5 mm	1000 mm	V0560201124	500

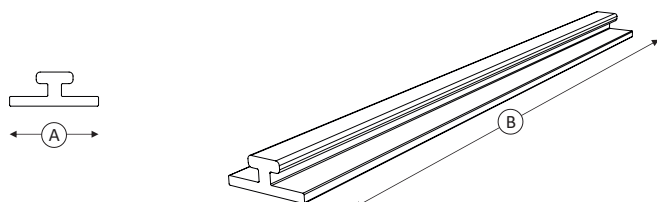

▶ OPTIMIZACIÓN DE LINEAL – PERFILES PARA DESLIZAMIENTO *SNAP-ON*



Consultar otras medidas

PERFIL CON CARRIL Deslizamiento central

CARACTERÍSTICAS

A	B	Color	Ref.	Uds. p/caja
40 mm	285 mm	TRANP. ○	V0560203630	300
40 mm	285 mm	NEGRO ●	V0560202994	300
40 mm	385 mm	TRANP. ○	V0560202871	150
40 mm	385 mm	NEGRO ●	V0560202831	150
40 mm	485 mm	TRANP. ○	V0560202870	150
40 mm	485 mm	NEGRO ●	V0560202832	150

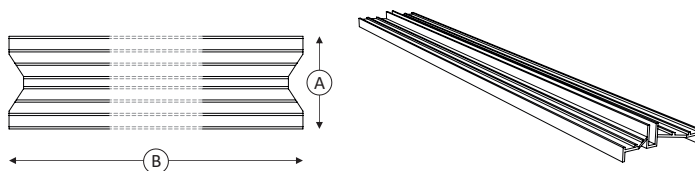

PERFIL CON CARRIL Deslizamiento dcho. /izdo.

CARACTERÍSTICAS

A	B	Color	Ref.	Uds. p/caja
40 mm	285 mm	TRANP. ○	V0560203559	600
40 mm	285 mm	NEGRO ●	V0560202996	600
40 mm	385 mm	TRANP. ○	V0560203507	300
40 mm	385 mm	NEGRO ●	V0560202907	300
40 mm	485 mm	TRANP. ○	V0560203608	300
40 mm	485 mm	NEGRO ●	V0560202908	300

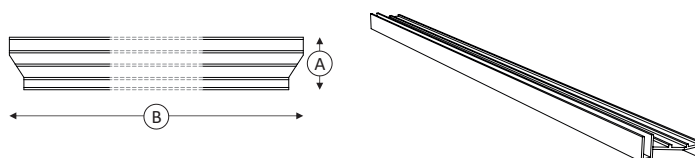

Consultar otras medidas





¡NOVEDAD!

NUEVOS DIVISORES *NEW VAGUE*

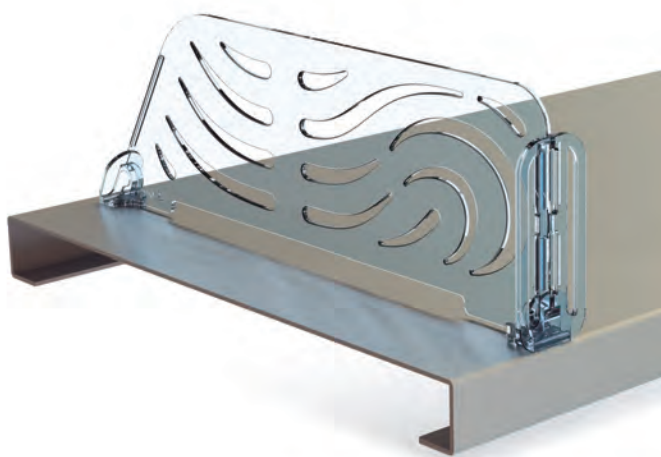



NUEVOS DIVISORES *NEW VAGUE*

- Sistema *SNAP-ON* en ambos extremos.
- Compatible con estantes horizontales y con inclinación a 30°.
- Alturas de 100 y 50 mm.
- Amplia variedad de longitudes disponibles.

¡NUEVO!

Frentes horizontales y de gravedad a su disposición

Compatibles con Empujadores y Retenedores *SNAP-ON* -págs. 115-123
Perfilería *SNAP-ON* -págs. 124-127

Divisibles

ALTURA DE 50 mm		
Longitud	Ref.	Uds. p/caja
185 - 385 mm	V0560117550	20



Altura de 50 mm

ALTURA DE 50 mm		
Longitud	Ref.	Uds. p/caja
285 mm	V0560112370	20
335 mm	V0560112371	20
385 mm	V0560112372	20
435 mm	V0560112373	20
485 mm	V0560112374	20
585 mm	V0560112375	20

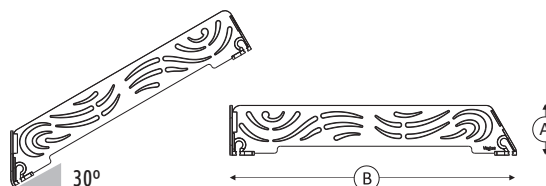

FRENTES PARA ESTANTES HORIZONTALES

ALTURA DE 50 mm			
	Longitud	Ref.	Uds. p/caja
Izquierda	23 mm	V0560112455	100
Central	35 mm	V0560112456	100
Derecha	23 mm	V0560112457	100

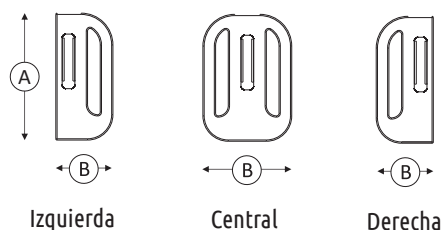

FRENTES PARA ESTANTERÍAS DE INCLINACIÓN A 30°

ALTURA DE 59 mm

	Profundidad	Ref.	Uds. p/caja
Izquierda	40 mm	V0560112458	100
Central	70 mm	V0560112459	100
Derecha	40 mm	V0560112460	100

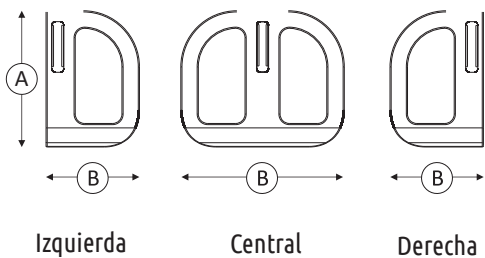

Compatibles con Empujadores y Retenedores *SNAP-ON* -págs. 115-123
Perfilería *SNAP-ON* -págs. 124-127

Altura de 100 mm

ALTURA DE 100 mm

	Profundidad	Ref.	Uds. p/caja
	285 mm	V0560112376	20
	335 mm	V0560112377	20
	385 mm	V0560112378	20
	435 mm	V0560112379	20
	485 mm	V0560112380	20
	585 mm	V0560112381	20

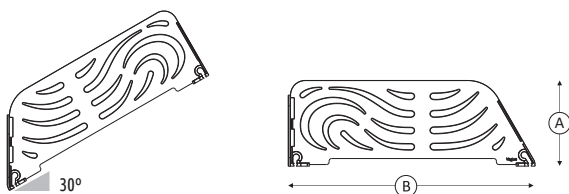

«Con sus diferentes formas se permite que fluya el frío de una manera más eficiente»

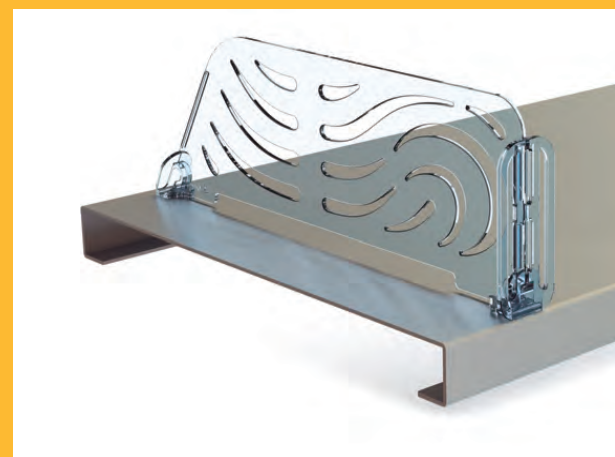

Divisible

ALTURA DE 100 mm

	Profundidad	Ref.	Uds. p/caja
	285 - 485 mm	V0560117654	20



FRENTES PARA ESTANTERÍAS HORIZONTALES



Compatibles con Empujadores y Retenedores *SNAP-ON* -págs. 115-123
Perfilería *SNAP-ON* -págs. 124-127

ALTURA DE 83 mm

	Profundidad	Ref.	Uds. p/caja
Izquierda	23 mm	V0560112461	100
Central	35 mm	V0560112462	100
Derecha	23 mm	V0560112463	200

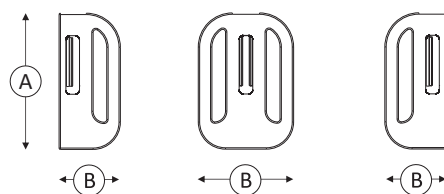

Izquierda

Central

Derecha



FRENTES PARA ESTANTERÍAS DE INCLINACIÓN A 30°



ALTURA DE 95 mm

	Profundidad	Ref.	Uds. p/caja
Izquierda	40 mm	V0560112464	100
Central	70 mm	V0560112465	100
Derecha	40 mm	V0560112466	100

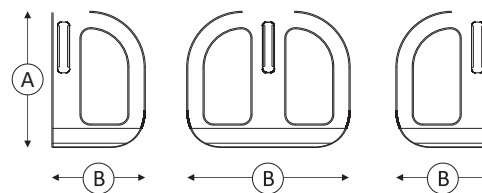

Izquierda

Central

Derecha



SEPARADOR EXCLUSIVO POINT CLIP®

Sistema de fijación ideal para campañas de lanzamiento o promociones especiales.

Imprime a todo color y con la forma deseada, incluso para pequeñas cantidades.

Puedes elegir entre multitud de materiales.

¡Consúltanos!





SEPARADOR CENTRAL Transparente

CARACTERÍSTICAS

A	B	Ref.	Uds. p/caja
100 mm	200 mm	V0560101027	60
150 mm	200 mm	V0560101028	35
200 mm	200 mm	V0560101029	20
200 mm	380 mm	V0560101036	30

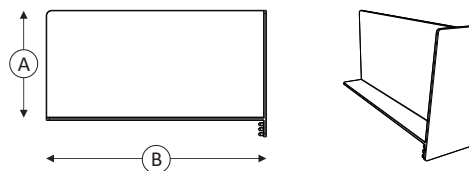

SEPARADOR DERECHO Transparente

CARACTERÍSTICAS

A	B	Ref.	Uds. p/caja
100 mm	200 mm	V0560101052	100
150 mm	200 mm	V0560101053	60
200 mm	200 mm	V0560101054	40

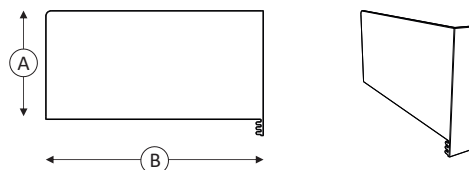

SEPARADOR IZQUIERDO Transparente

CARACTERÍSTICAS

A	B	Ref.	Uds. p/caja
100 mm	200 mm	V0560101070	100
150 mm	200 mm	V0560101071	60
150 mm	300 mm	V0560101058	20
200 mm	200 mm	V0560101068	40
100 mm	300 mm	V0560101075	30

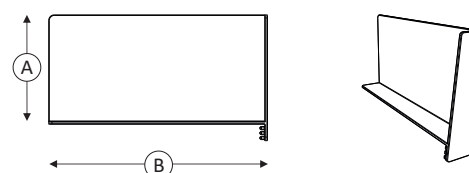

SEPARADOR CENTRAL con trasera a 45°

CARACTERÍSTICAS

A	B	Ref.	Uds. p/caja
150 mm	300 mm	V0560101033	20
100 mm	300 mm	V0560101032	50

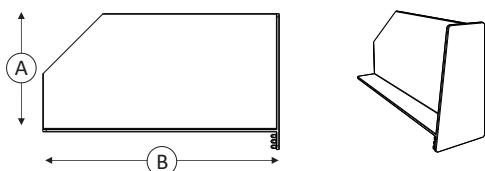

SEPARADOR IZQUIERDO con trasera a 45°

CARACTERÍSTICAS

A	B	Ref.	Uds. p/caja
150 mm	300 mm	V0560101058	20
100 mm	300 mm	V0560101075	30

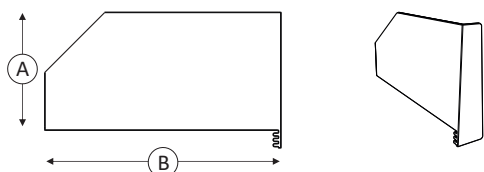

SEPARADOR DERECHO con trasera a 45°

CARACTERÍSTICAS

A	B	Ref.	Uds. p/caja
150 mm	300 mm	V0560101076	20
100 mm	300 mm	V0560101057	30

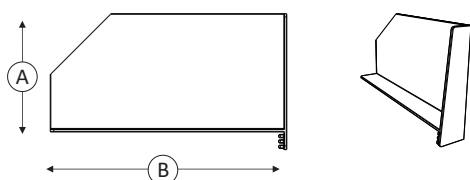



SEPARADOR CENTRAL

CARACTERÍSTICAS

A	B	Ref.	Uds. p/caja
60 mm	200 mm	V0560101030	55
60 mm	300 mm	V0560101034	90
60 mm	355 mm	V0560101035	90

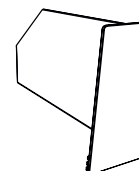
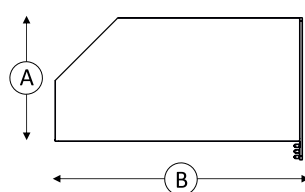

SEPARADOR IZQUIERDO

CARACTERÍSTICAS

A	B	Ref.	Uds. p/caja
60 mm	200 mm	V0560101072	55
60 mm	300 mm	V0560101077	55
60 mm	355 mm	V0560101078	55

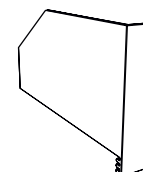
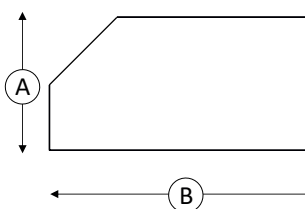

SEPARADOR DERECHO

CARACTERÍSTICAS

A	B	Ref.	Uds. p/caja
100 mm	200 mm	V0560101052	100
200 mm	150 mm	V0560101053	60
200 mm	200 mm	V0560101054	40

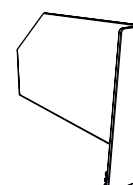
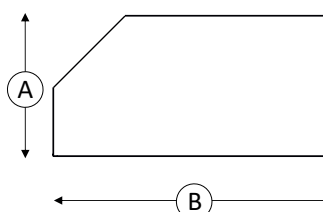

▶ OPTIMIZACIÓN DE LINEAL - SEPARADORES TEGO



SEPARADOR - ALTURA 45 mm

CARACTERÍSTICAS

A	B	Ref.	Uds. p/caja
45 mm	200 mm	V0560101219	150
45 mm	250 mm	V0560101224	100
45 mm	300 mm	V0560101228	50
45 mm	370 mm	V0560101232	50
45 mm	470 mm	V0560101238	50
45 mm	570 mm	V0560101243	50

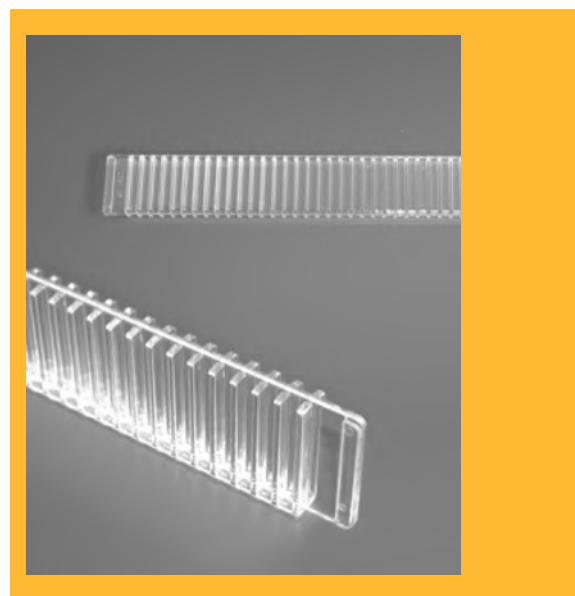
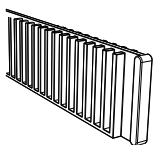
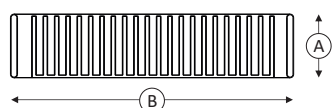

SEPARADOR - ALTURA 75 mm

CARACTERÍSTICAS

A	B	Ref.	Uds. p/caja
75 mm	200 mm	V0560101220	100
75 mm	250 mm	V0560101225	50
75 mm	300 mm	V0560101229	50
75 mm	370 mm	V0560101233	50
75 mm	470 mm	V0560101239	50
75 mm	570 mm	V0560101244	50

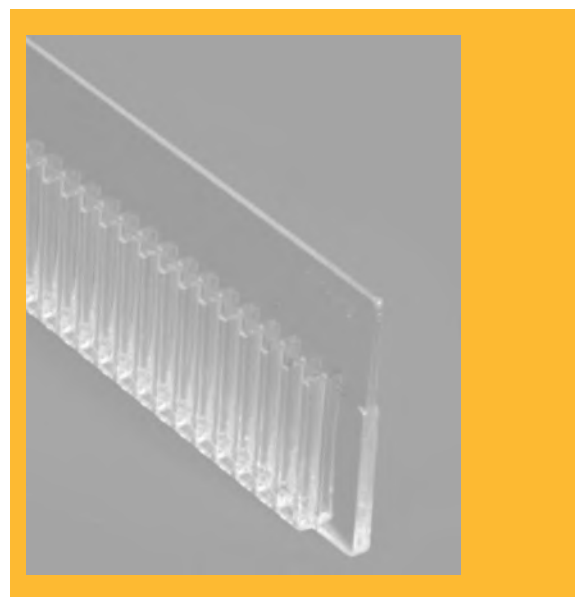
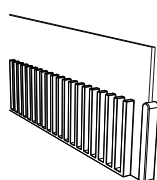
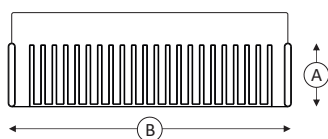

SEPARADOR 45 - 75 mm

CARACTERÍSTICAS

A	B	Ref.	Uds. p/caja
45 mm	177 mm	V0560101217	200
75 mm	177 mm	V0560101218	200
45 mm	343 mm	V0560101230	150
75 mm	343 mm	V0560101231	100
45 mm	443 mm	V0560101236	150
75 mm	443 mm	V0560101237	100

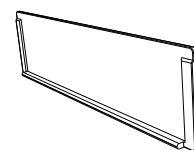

Consultar otras medidas

SEPARADOR 45 - 75 mm

CARACTERÍSTICAS

A	B	Ref.	Uds. p/caja
45 mm	84 mm	V0560101249	150
75 mm	84 mm	V0560101250	150
75 mm	168 mm	V0560101215	150
75 mm	168 mm	V0560101216	200

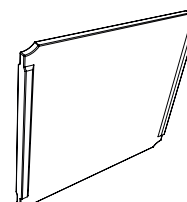
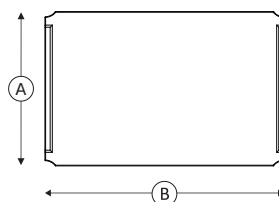

ELEVADOR DELANTERO para vidrio

CARACTERÍSTICAS				
	A	B	Ref.	Uds. p/caja
Vidrio 8 mm	18 mm	1000 mm	V0560101212	100
Vidrio 10 mm	20 mm	1000 mm	V0560101213	225

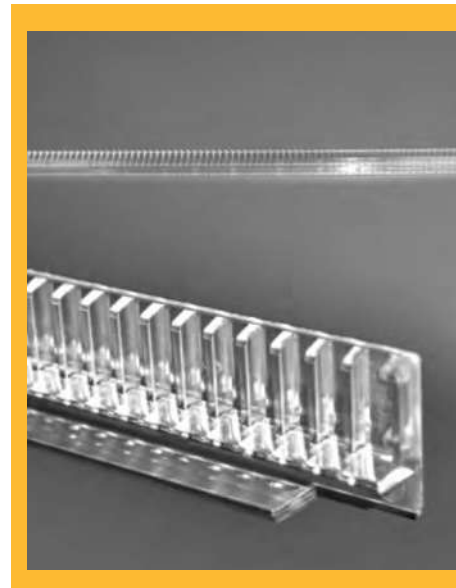
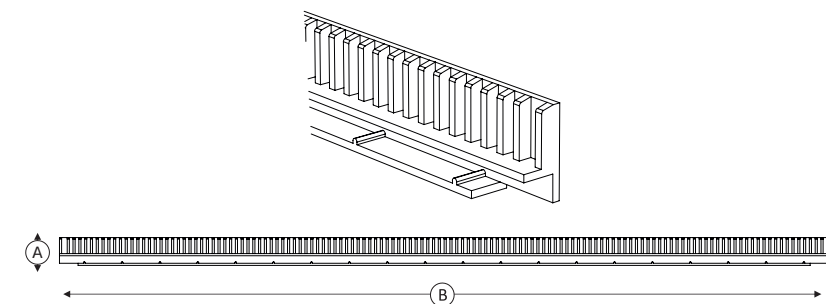

ELEVADOR DELANTERO con dientes

CARACTERÍSTICAS				
	A	B	Ref.	Uds. p/caja
	45 mm	665 mm	V0560101246	75
	45 mm	1000 mm	V0560101098	75
	45 mm	1217 mm	V0560103087	75
	45 mm	1250 mm	V0560101102	75
	45 mm	1330 mm	V0560101103	75

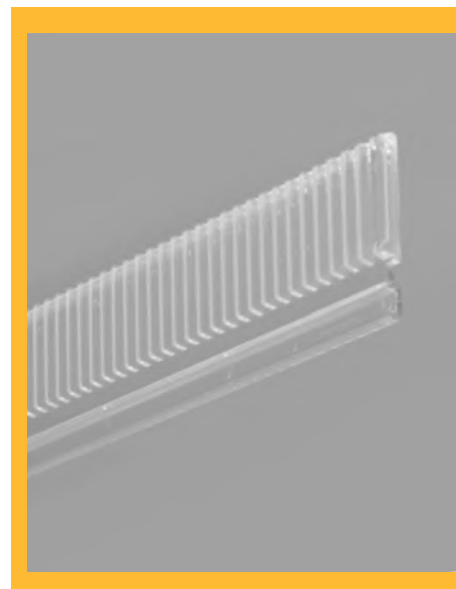
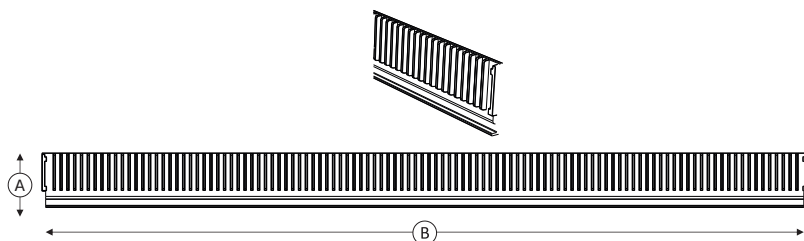

ELEVADOR DELANTERO con dientes

CARACTERÍSTICAS				
	A	B	Ref.	Uds. p/caja
	45 mm	1000 mm	V0560101097	75
*	45 mm	1000 mm	V0560101096	75

*para estantes MARGO

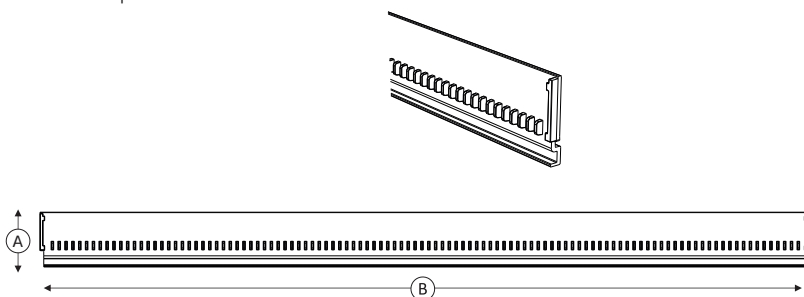

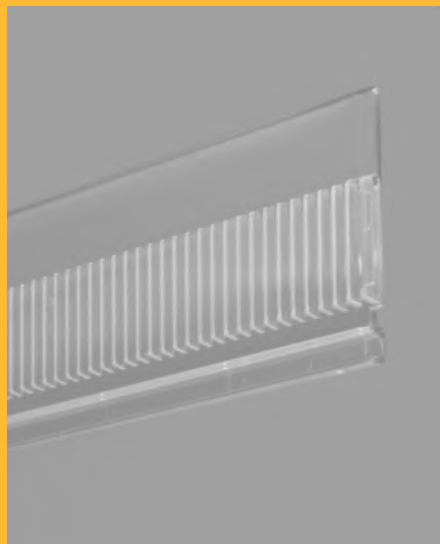

ELEVADOR DELANTERO con dientes

CARACTERÍSTICAS			
A	B	Ref.	Uds. p/caja
75 mm	665 mm	V0560101247	50
75 mm	1000 mm	V0560101100	50
* 75 mm	1000 mm	V0560102627	50
75 mm	1217 mm	V0560103088	50
75 mm	1250 mm	V0560101092	50
75 mm	1330 mm	V0560101104	50

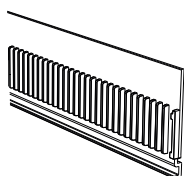

*En color gris ●

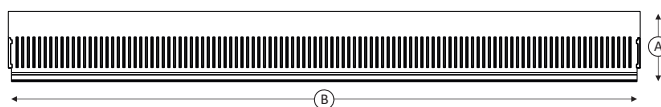

ELEVADOR DELANTERO 75 mm

CARACTERÍSTICAS			
A	B	Ref.	Uds. p/caja
75 mm	1000 mm	V0560101101	50
* 75 mm	1000 mm	V0560101099	50

*para estantes MARGO

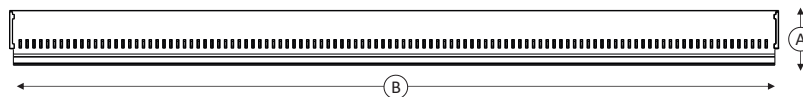
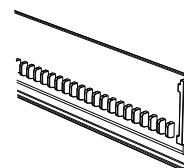

ELEVADOR DELANTERO 75 - 100 mm

CARACTERÍSTICAS			
A	B	Ref.	Uds. p/caja
75 mm	1000 mm	V0560103354	50
100 mm	1330 mm	V0560103628	50
100 mm	1000 mm	V0560103629	40

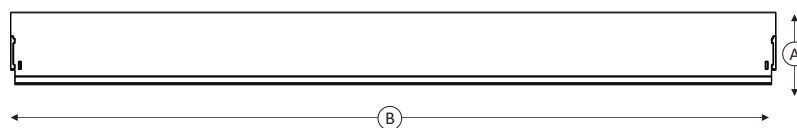
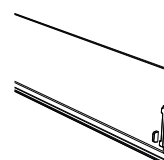

▶ OPTIMIZACIÓN DE LINEAL - SEPARADORES CRISTAL/MADERA

SEPARADOR 20 mm

CARACTERÍSTICAS

A	B	Ref.	Uds. p/caja
20 mm	250 mm	V0560101223	200
20 mm	375 mm	V0560101234	200

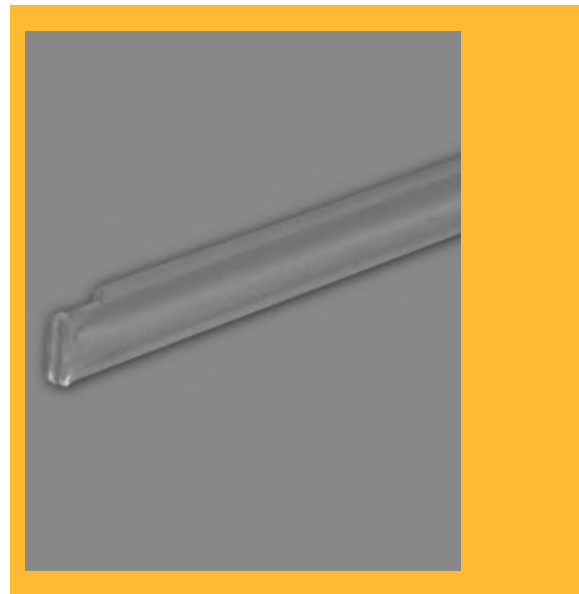
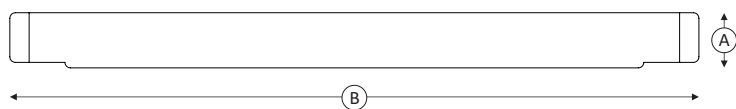
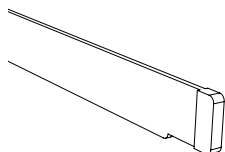

SEPARADOR 65 mm (para estantería de farmacia)

CARACTERÍSTICAS

A	B	Ref.	Uds. p/caja
65 mm	180 mm	V0560101211	150

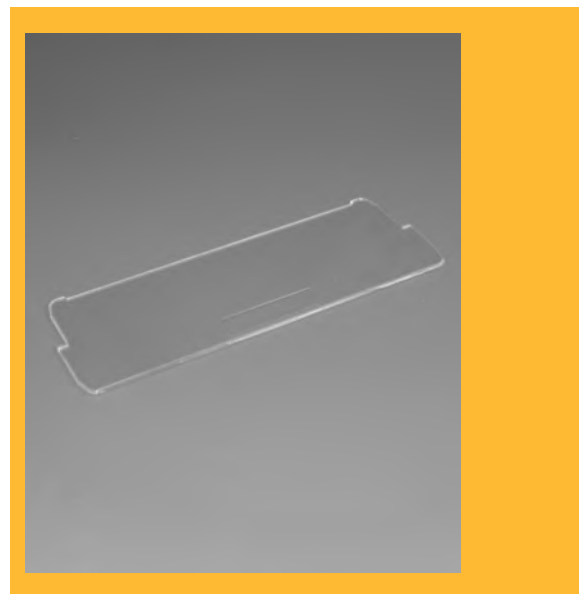
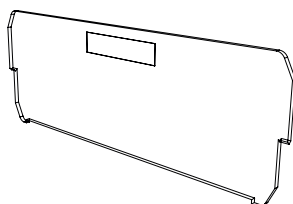
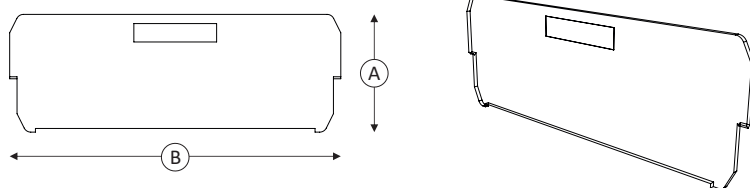

SOPORTE 35 mm (separador de vidrio)

CARACTERÍSTICAS

A	B	C	Ref.	Uds. p/caja
35 mm	60 mm	10 mm	V0560101105	400

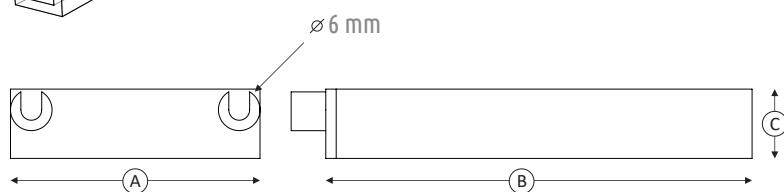
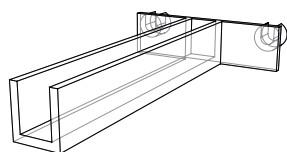



**ESPECIALISTAS
EN**

**OPTIMIZADORES
PARA LINEAL**

¡CONSÚLTANOS!

▶ OPTIMIZACIÓN DE LINEAL - SEPARADORES CRISTAL/MADERA

CLIP DIVISOR para perfil trasero

CARACTERÍSTICAS

A	Ref.	Uds. p/caja
220 mm	V0560100919	100

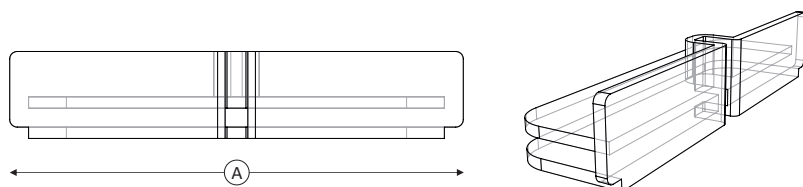

PERFIL TRASERO (color gris)

CARACTERÍSTICAS

A	B	Ref.	Uds. p/caja
230 mm	183 mm	V0560201199	40
230 mm	567 mm	V0560201200	20

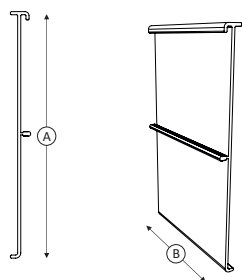

Consultar otras medidas

CLIP DIVISOR para perfil delantero

CARACTERÍSTICAS

A	Ref.	Uds. p/caja
75 mm	V0560100918	150

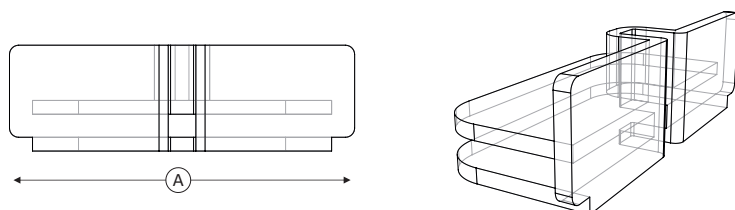



PERFIL DELANTERO

CARACTERÍSTICAS

A	B	Ref.	Uds. p/caja
80 mm	997 mm	V0560201198	30

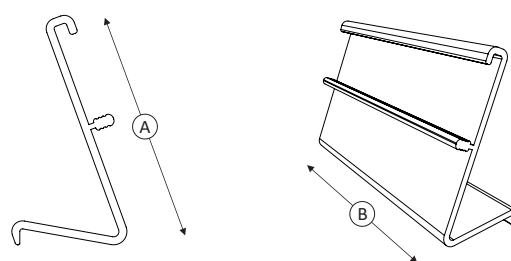

DIVISOR DELANTERO

CARACTERÍSTICAS

A	B	Ref.	Uds. p/caja
40 mm	665 mm	V0560100924	150
40 mm	1250 mm	V0560100920	150

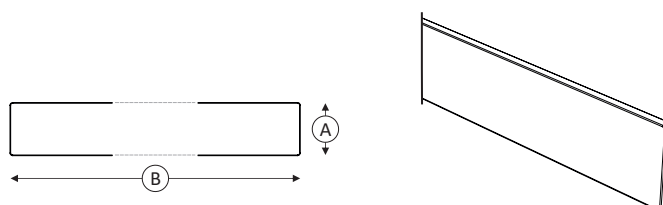

Consultar otras medidas



DIVISOR DELANTERO

CARACTERÍSTICAS

A	B	Ref.	Uds. p/caja
40 mm	900 mm	V0560101015	150
40 mm	964 mm	V0560101017	150
40 mm	994 mm	V0560101094	75
40 mm	1250 mm	V0560101091	100
80 mm	964 mm	V0560101016	75
80 mm	994 mm	V0560101095	45

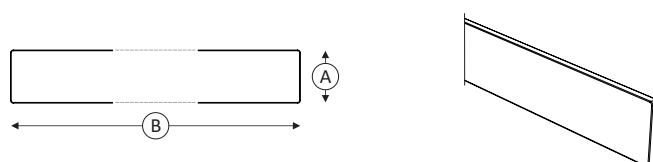

Consultar otras medidas

▶ OPTIMIZACIÓN DE LINEAL - SEPARADORES CRISTAL/MADERA

TIRA de indicación de vidrio de 4 mm

CARACTERÍSTICAS

A	B	Ref.	Uds. p/caja
30 mm	400 mm	V0560100977	100
30 mm	400 mm	V0560100980	100

*

*Con adhesivo blanco

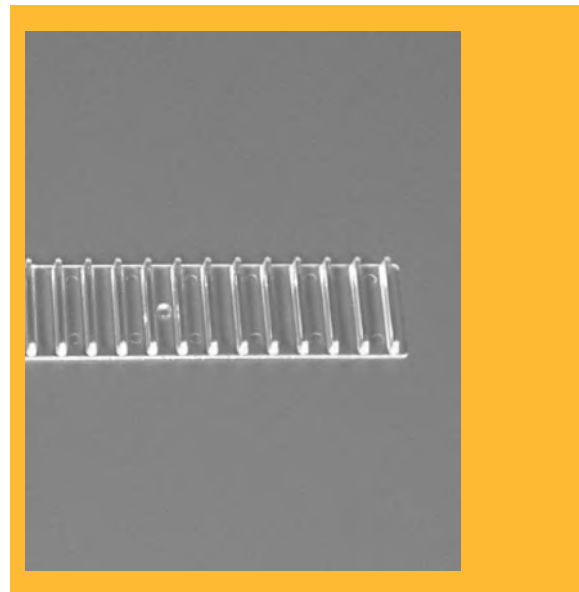
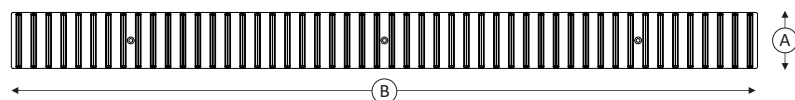
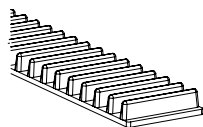

TIRA de indicación de vidrio de 4 mm

CARACTERÍSTICAS

A	B	Ref.	Uds. p/caja
10 mm	400 mm	V0560100971	200
10 mm	400 mm	V0560100975	200

*

*Con adhesivo blanco

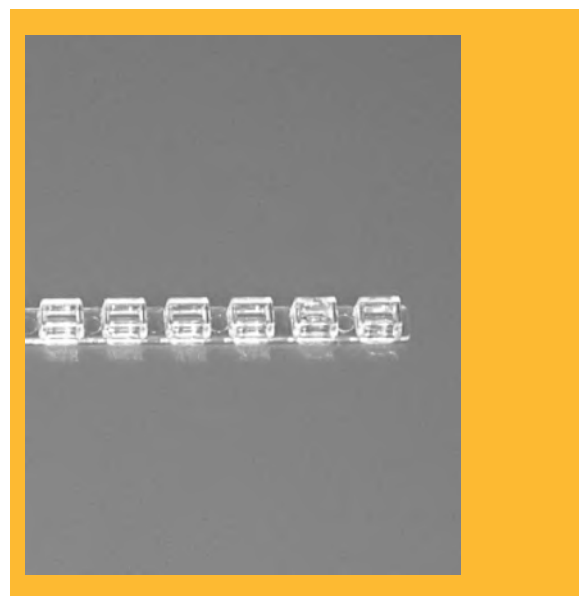
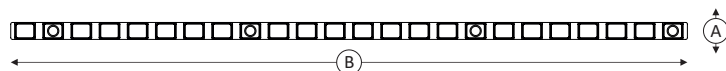
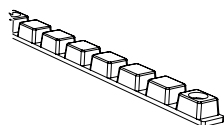

TIRA de indicación de vidrio de 4 mm (gris)

CARACTERÍSTICAS

A	B	Ref.	Uds. p/caja
30 mm	400 mm	V0560100978	100

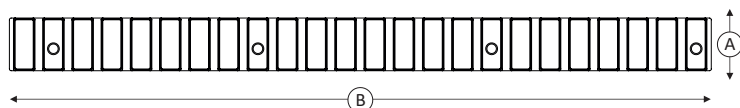
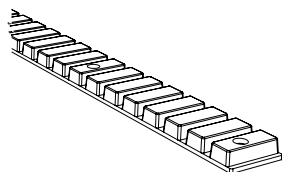

▶ OPTIMIZACIÓN DE LINEAL - SEPARADORES CRISTAL/MADERA



TIRA de indicación de vidrio de 4 mm

CARACTERÍSTICAS

A	B	Ref.	Uds. p/caja
30 mm	400 mm	V0560100979	100

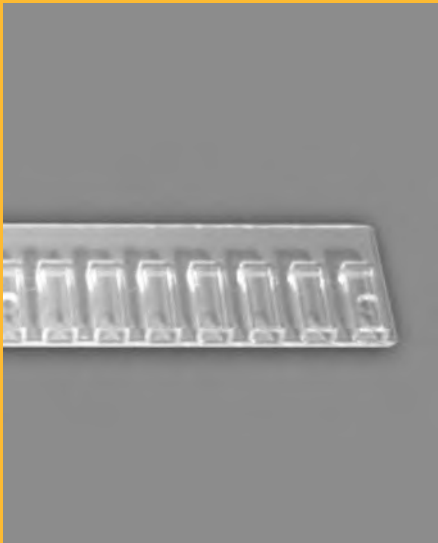
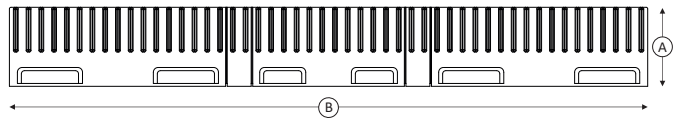
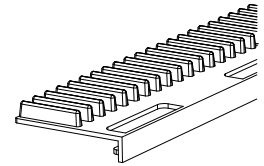

TIRA de indicación de vidrio de 4 mm

CARACTERÍSTICAS

A	B	Ref.	Uds. p/caja
50 mm	400 mm	V0560100982	100

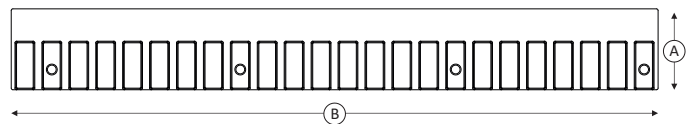
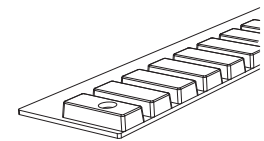

TIRA de indicación de vidrio de 4 mm

CARACTERÍSTICAS

A	B	Ref.	Uds. p/caja
10 mm	400 mm	V0560100973	200
* 10 mm	400 mm	V0560100974	200

*Con adhesivo blanco

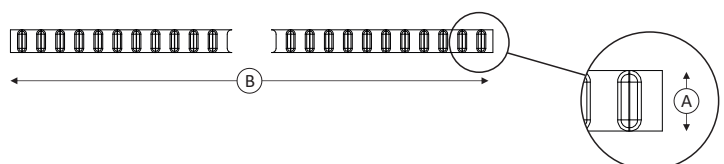
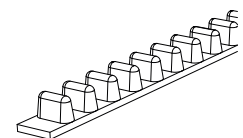

▶ OPTIMIZACIÓN DE LINEAL - SEPARADORES CRISTAL/MADERA

ELEVADOR - Delantero dentado 35 mm

CARACTERÍSTICAS

A	B	Ref.	Uds. p/caja
35 mm	488 mm	V0560101240	150
35 mm	609 mm	V0560101245	150
35 mm	887 mm	V0560101251	150
35 mm	1237 mm	V0560101214	150

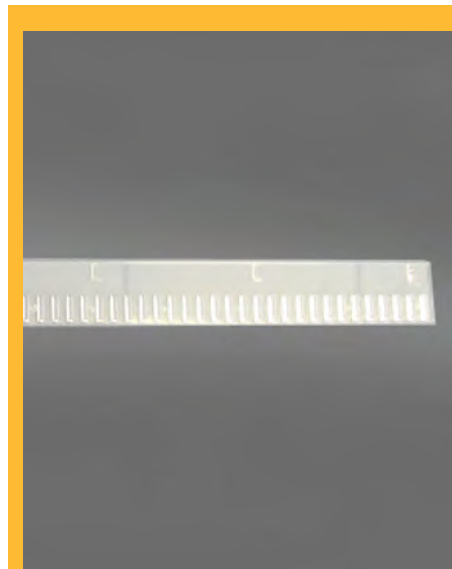
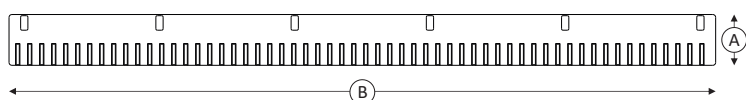
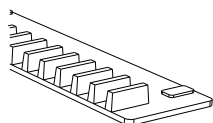

DIVISOR 30 mm

CARACTERÍSTICAS

A	B	Ref.	Uds. p/caja
30 mm	400 mm	V0560100976	100

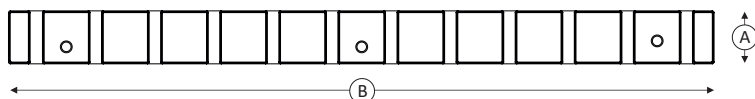
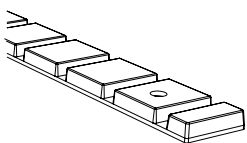

TIRA de indicación de vidrio de 6 mm

CARACTERÍSTICAS

A	B	Ref.	Uds. p/caja
50 mm	400 mm	V0560100981	100

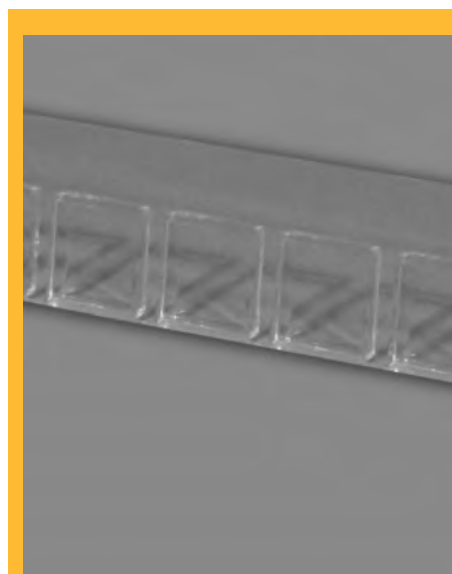
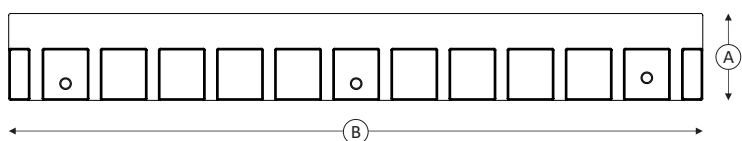
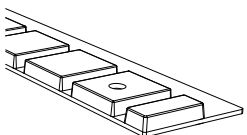

▶ OPTIMIZACIÓN DE LINEA - SEPARADORES CRISTAL/MADERAL

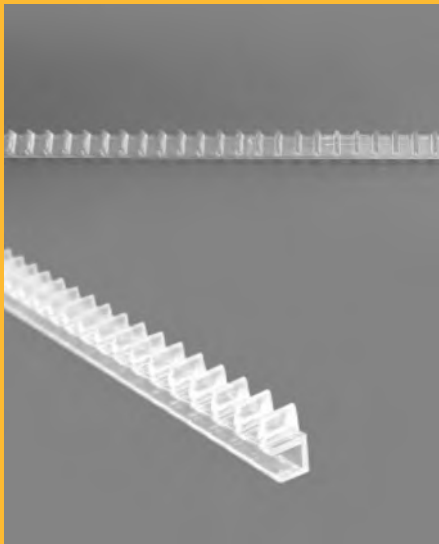

TIRA de indicación de vidrio de 4 mm (gris)

CARACTERÍSTICAS

A	B	Ref.	Uds. p/caja
10 mm	400 mm	V0560100972	200

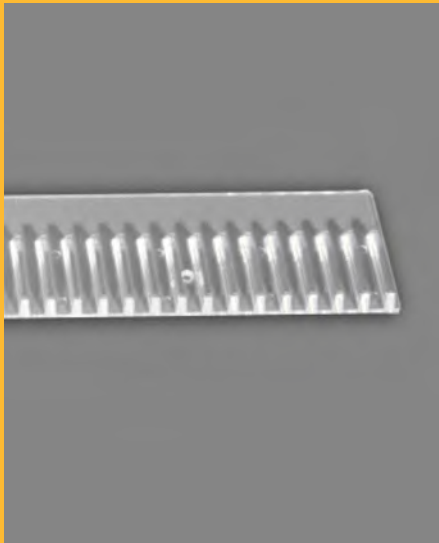
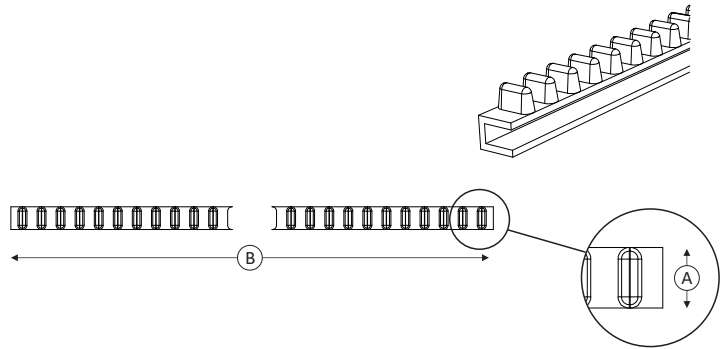

TIRA de indicación de vidrio de 4 mm

CARACTERÍSTICAS

A	B	Ref.	Uds. p/caja
50 mm	400 mm	V0560100983	100
* 50 mm	400 mm	V0560100984	100

*Con adhesivo

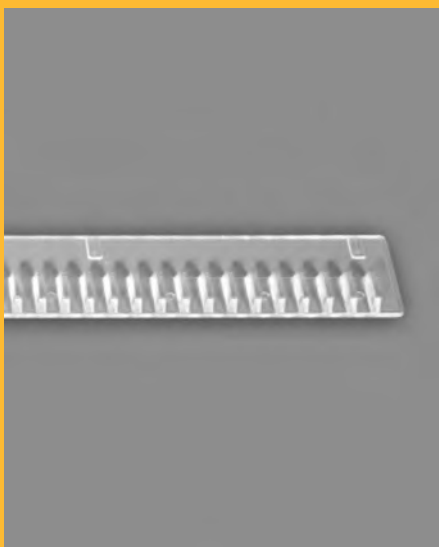
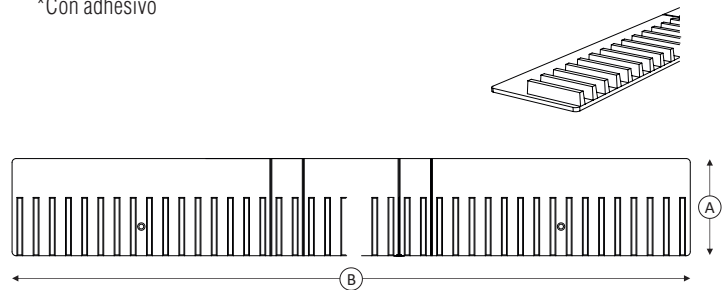

TIRA de indicación de vidrio de 4 mm

CARACTERÍSTICAS

A	B	Ref.	Uds. p/caja
50 mm	710 mm	V0560101248	75

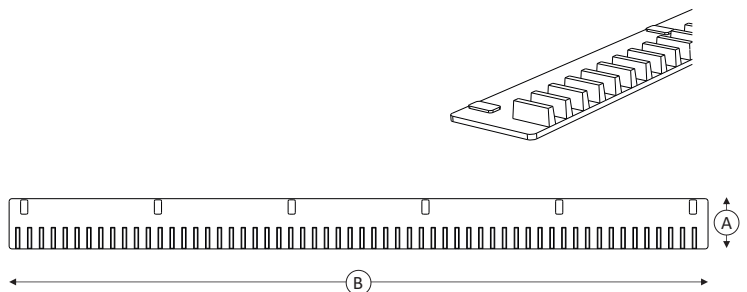



Empujador pizza Duo HIPS

- Especial para sistema *SNAP-ON*

CARACTERÍSTICAS

Dimensiones	FUERZA (Newton)	Ref.
485x270	12 N	V0560118931
485x310	12 N	V0560118932



Empujador pizza con estructura metálica

CARACTERÍSTICAS

Dimensiones	FUERZA (Newton)	Ref.
400x180	12 N	V0560418963

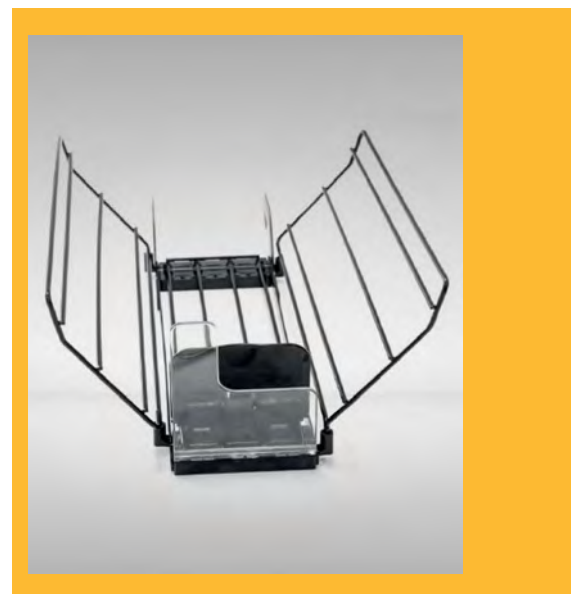

Barra de carga ajustable

Ref.
V0150417916



ORGANIZADORES A MEDIDA

Todos ellos están hechos en materias primas de la más alta calidad, asegurando una larga duración y una manipulación correcta de alimentos. Mejora la organización y el atractivo visual de las secciones de congelados.

Disponible en tamaños estándar, pero también se pueden hacer a medida para cumplir con las especificaciones y necesidades de cada cliente.



CAJAS PARA REFRIGERADOS

- Cajas para productos congelados integrados.
- Aplicable en sistemas de refrigeración y congeladores.
- Material flexible, muy resistente y lavable.



CAJA para productos congelados

CARACTERÍSTICAS

A	B	C	Ref.	Uds. p/caja
360 mm	200 mm	270 mm	V0750807601	4
395 mm	250 mm	270 mm	V0750807600	4
790 mm	200 mm	290 mm	V0750807599	2
790 mm	200 mm	330 mm	V0750807610	2
790 mm	250 mm	270 mm	V0750807543	2
790 mm	250 mm	290 mm	V0750807598	2
790 mm	250 mm	330 mm	V0750807609	2

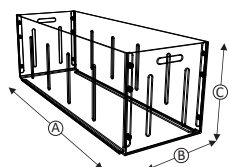

SEPARADOR para cajas de congelados

CARACTERÍSTICAS

A	B	Ref.	Uds. p/caja
225 mm	260 mm	V0560807477	12
225 mm	280 mm	V0560807478	12
235 mm	260 mm	V0560807602	12
235 mm	270 mm	V0560807611	12
235 mm	280 mm	V0560807603	12

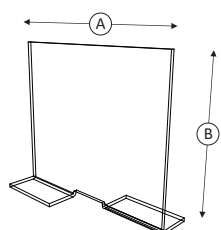

▶ OPTIMIZADORES PARA REFRIGERADOS



SEPARADOR para cajas de congelados

CARACTERÍSTICAS

A	B	Ref.	Uds. p/caja
800 mm	120 mm	V0560807283	4
800 mm	150 mm	V0560807761	4

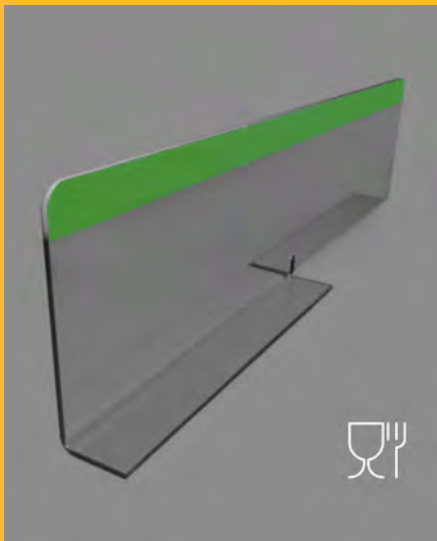
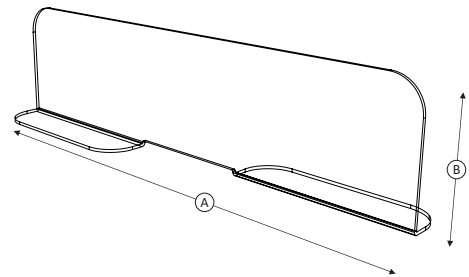

SEPARADOR personalizado con vinilo

CARACTERÍSTICAS

A	B	Ref.	Uds. p/caja
800 mm	150 mm	V0560807595	4

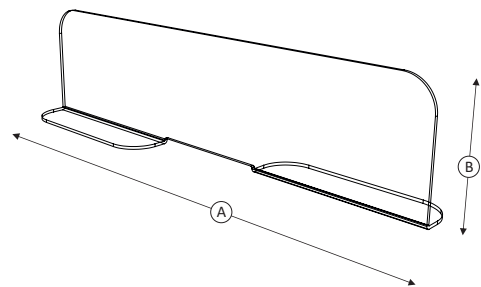

Separadores decorados

PERSONALIZA TU SEPARADOR

- Con logotipos, imágenes y formas
- Para estas opciones y otros colores o dimensiones, por favor ponte en contacto con nosotros.

▶ OPTIMIZADORES PARA REFRIGERADOS

SEPARADOR (esquinas redondeadas)

CARACTERÍSTICAS

A	B	Ref.	Uds. p/caja
800 mm	200 mm	V0560814341	4

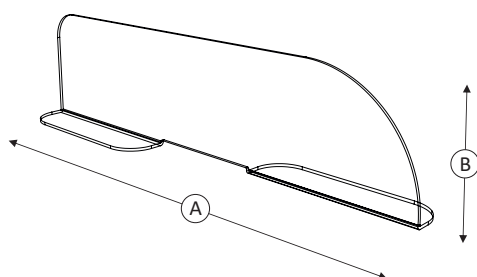

SEPARADOR EN "T"

CARACTERÍSTICAS

A	B	Ref.	Uds. p/caja
40 mm	1000 mm	V0560203731	50
50 mm	1000 mm	V0560203730	50
80 mm	1000 mm	V0560203732	30

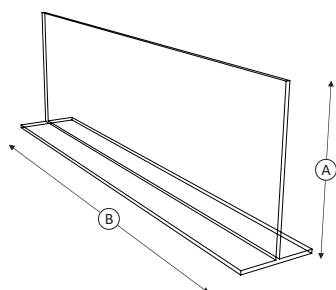

SOPORTE de precios para refrigerados

CARACTERÍSTICAS

Dimensiones	Ref.	Uds. p/caja
300 x 120 mm	V0570814030	25
330 x 100 mm	V0570814172	25

Ⓐ

Ⓑ

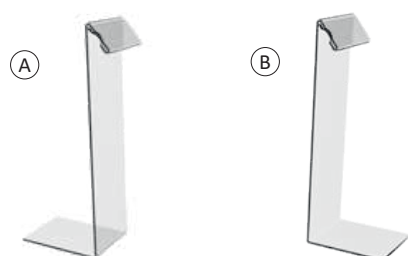

DISPENSADORES DE PRODUCTOS A GRANEL

Disponemos de una variedad de dispensadores los cuales combinan flexibilidad y funcionalidad sin descuidar el diseño.

Proporcionan un aumento de ventas del 25% al 35%. Soluciones de *merchandising* que agilizan el lineal, haciéndolo más atractivo.

El cliente compra la cantidad deseada.
Manejo sencillo y eficaz.
Seguridad alimentaria garantizada.



DISPENSADOR GENBOX

Genbox aumenta las ventas y la optimización del espacio. Optimiza la visualización del lineal y lo hace más atractivo. Reduce la cantidad de productos envasados y en consecuencia, otros costes directamente asociados como el transporte.

Fácil de limpiar y mantener.

El cliente compra la cantidad deseada.

Manejo sencillo y eficaz.

Seguridad alimentaria garantizada.

¡NUEVO!



**Reusable
Recycled
Recyclable**



▶ DISPENSADORES PARA PRODUCTOS A GRANEL



DISPENSADOR GENBOX

Dispensador con sistema de gravedad de alta resistencia. Sellado herméticamente para proteger los productos del contacto externo, respeta los estándares de contacto con alimentos.



Alimentos Seguros



Tapa Segura



Fácil Instalación



Lavable en Máquina

Elige entre la versión de 8 y 13 litros de capacidad.

UNA EXPERIENCIA DE COMPRA SEGURA Y TRANSPARENTE



Fabricado en material súper transparente, duradero, de alto impacto y reciclable.

Diseño de rotación de *stock* (primero en entrar, primero en salir) manteniendo la rotación de productos constante.

A diferencia de los envases abiertos, nuestros dispensadores sellan la frescura y protegen del aire exterior. Permiten controlar las porciones y el flujo reduciendo desechos alimentarios.



▶ DISPENSADORES PARA PRODUCTOS A GRANEL

GENBOX 8 Litros

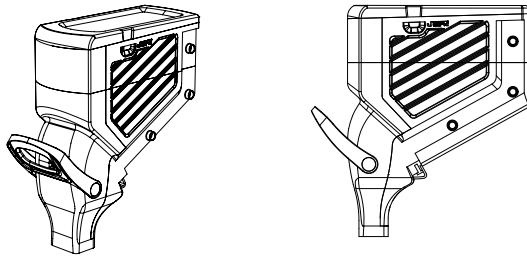

CARACTERÍSTICAS

Dimensiones	Color	Ref.	Uds. p/caja
150x370x435	TRANSP. ○	V0150118525	2



GENBOX 13 litros

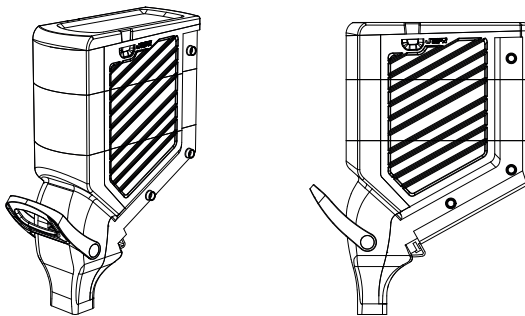

CARACTERÍSTICAS

Dimensiones	Color	Ref.	Uds. p/caja
150x370x570	TRANSP. ○	V0150118526	2



Fácil instalación, mantenimiento y limpieza - Manejo sencillo y eficaz



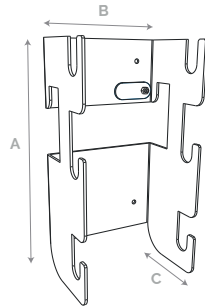

SOPORTE GENBOX
MOD. 8/13 litros

CARACTERÍSTICAS

A	B	C	Color	Ref.	Uds. p/caja
270	144	100	RAL 9005 ●	V0150419430	1



Nivel 1 Nivel 2 Nivel 3

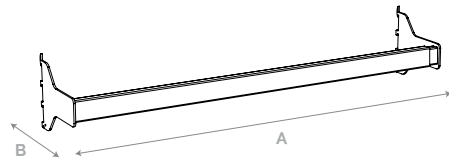

BARRAS DE SOPORTE
TELESCÓPICAS

CARACTERÍSTICAS

	A	B	Color	Ref.	Uds. p/caja
Nivel 1	1000-1330	65	RAL 9005 ●	V0150419687	1
Nivel 2	1000-1330	180	RAL 9005 ●	V0150419685	1
Nivel 3	1000-1330	245	RAL 9005 ●	V0150419681	1

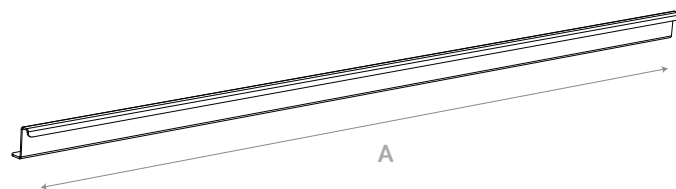

PERFIL
GENBOX

CARACTERÍSTICAS

A	Color	Ref.	Uds. p/caja
1000	RAL 9005 ●	V0150419638	1

▶ ACCESORIOS GENBOX

SOPORTE PERFIL GENBOX 8/13 Litros

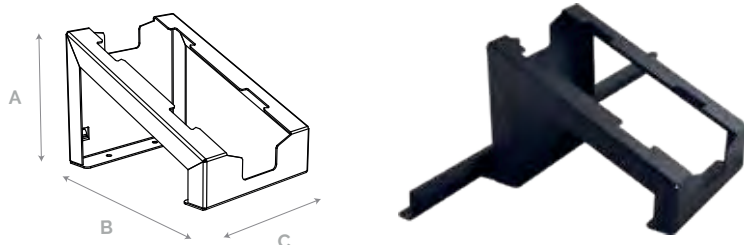

CARACTERÍSTICAS

A	B	C	Color	Ref.	Uds. p/caja
150	205	160	RAL 9005 ●	V0150419432	1

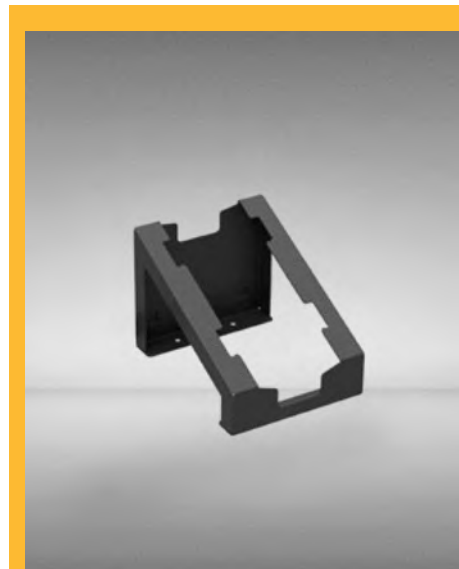

ESTANTE PARA FIJACIÓN

CARACTERÍSTICAS

Dimensiones	Color	Ref.	Uds. p/caja
1000x215x163	RAL 9005 ●	V0150419434	1



SOPORTE VERTICAL



CARACTERÍSTICAS

Dimensiones	Color	Ref.	Uds. p/caja
150	RAL 9005 ●	V0150419431	1



¡NUEVO!

DISPENSADOR *TURNOFLEX*®

Este modelo de dispensador cuenta con tres versiones 4,5 ; 6,5 y 10 litros de capacidad para una mayor versatilidad. El mecanismo de distribución giratorio evita el desperdicio, facilita el flujo de productos y proporciona a los clientes las cantidades exactas.

Recarga fácil para simplificar el abastecimiento, la tapa sirve como sistema de soporte.

Este sistema se puede fijar a estantes o soportes.



**Alimentos
Seguros**



**Tapa
Segura**



**Fácil
Instalación**



**Lavable en
Máquina**



▶ DISPENSADORES PARA PRODUCTOS A GRANEL

TURNOFLEX®

4,5 Litros

- Dimensiones en el siguiente orden: ancho / fondo / alto
- Sistema compatible con *Genbox* 8 litros.

CARACTERÍSTICAS

Dimensiones	Color	Ref.
145x250x350	TRANSP. ○	V0150419439



TURNOFLEX®

6,5 Litros

- Dimensiones en el siguiente orden: ancho / fondo / alto
- Sistema compatible con *Genbox* 8 litros.

CARACTERÍSTICAS

Dimensiones	Color	Ref.
145x250x390	TRANSP. ○	V0150419437

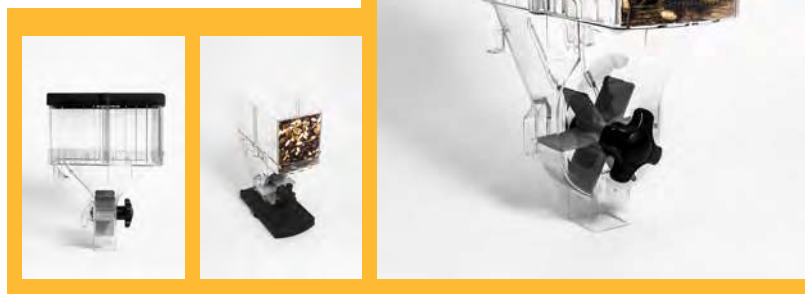

TURNOFLEX®

10 Litros

- Dimensiones en el siguiente orden: ancho / fondo / alto
- Sistema compatible con *Genbox* 8 litros.

CARACTERÍSTICAS

Dimensiones	Color	Ref.
145x250x501	TRANSP. ○	V0150419435



PERFIL DE FIJACIÓN



CARACTERÍSTICAS

	Dimensiones	Color	Ref.
Nivel 3	1000X245	RAL 9005 ●	V0150419440
	1330X245	RAL 9005 ●	V0150419441
	1000X150	RAL 9005 ●	V0150419442
Nivel 2	1330X150	RAL 9005 ●	V0150419659
	1000X180	RAL 9005 ●	V0150419658

SOPORTE PARA BARRAS



- Soporte para barra de apoyo de 50x25mm
- Con llave de seguridad

CARACTERÍSTICAS

Dimensiones	Color	Ref.
150 mm	RAL 9005 ●	V0150419438

SOPORTES PARA BOLSAS



CARACTERÍSTICAS

	Dimensiones	Color	Ref.
Soporte Carril	150 mm	RAL 9005 ●	V0150419660
	1000 mm	RAL 9005 ●	V0150419661

SOPORTE PARA BALANZAS

- Dimensiones en el siguiente orden: ancho / fondo / alto.

CARACTERÍSTICAS

Dimensiones	Color	Ref.	
1000x215x163	RAL 9005 ●	V0150419662	Nivel 1
1330x215x163	RAL 9005 ●	V0150419663	
1000x364x163	RAL 9005 ●	V0150419664	Nivel 2
1330x364x163	RAL 9005 ●	V0150419665	

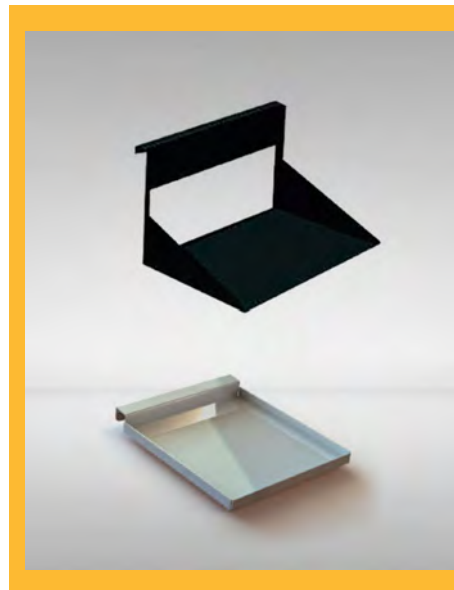

BANDEJA DE RECUPERACIÓN

- Dimensiones en el siguiente orden: ancho / fondo.

CARACTERÍSTICAS

Dimensiones	Color	Ref.
1000x245 mm	RAL 9005 ●	V0750816984
1330x245 mm	RAL 9005 ●	V0750819666

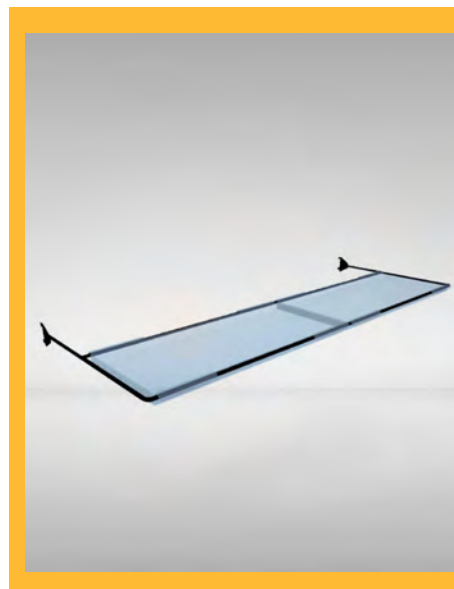

TANQUE DE RECUPERACIÓN

- Dimensiones en el siguiente orden: ancho / fondo.
- Barras de soporte telescópicas antideslizantes.
- Pasos de 50 mm a 25 mm.

CARACTERÍSTICAS

Dimensiones	Color	Ref.
1000x245 mm	RAL 9005 ●	V0150419667
1000x150 mm	RAL 9005 ●	V0150419669
1330x150 mm	RAL 9005 ●	V0150419670
1000x180 mm	RAL 9005 ●	V0150419671
1330x180 mm	RAL 9005 ●	V0150419672
1000x65 mm	RAL 9005 ●	V0150419673





PEDESTAL
GENBOX / TURNOFLEX

- Soporte para barra de apoyo de 50x25 mm
- Con llave de seguridad

CARACTERÍSTICAS

Dimensiones	Color	Ref.
150 mm	RAL 9005 ●	V0150419674



CARRO DE MANTENIMIENTO

Servicio de limpieza *GENBOX / TURNOFLEX*

- 1 caja de colector *Genbox* de 100 mm
- 1 caja de colector *Genbox* de 150 mm
- 1 caja de receptor *Turnoflex*® - Soporte 1 bolsa
- 1 estante de almacenamiento para productos de limpieza
- 1 escoba - 1 bandeja de trabajo
- 1 bandeja de almacenamiento
- 4 ruedas, 2 de ellas con freno

CARACTERÍSTICAS

Dimensiones	Color	Ref.
150 mm	RAL 9005 ●	V0150419675



**La solución que beneficia
al mercado minorista,
a los clientes y
al medio ambiente.**

QUICKBOX

15,5 Litros

- Diseñado para ser fijado a una bandeja o barra de soporte.
- Tiene capacidad para 15,5 litros.
- Tiene un sistema de autocierre.

CARACTERÍSTICAS

Dimensiones	Color	Ref.
150 mm	RAL 9005 ●	V0150410390



PRIBOX
DIVISIBLE

- Se puede dividir el tanque principal en 3 compartimentos.
- Compuesto por un tanque principal 1 x 15 litros, 2 x 7,5 litros o 3 x 5 litros.
- Tiene tapa de apertura frontal con sistema de cierre automático hermético.
- Dispone de sistema de apertura posterior para el llenado.

CARACTERÍSTICAS

Dimensiones	Color	Ref.
150 mm	RAL 9005 ●	V0150115980

